

**SERVICES INDUSTRIELS
SAVARIA INC.**

BATTERY OPERATED B.07 G

OWNER'S MANUAL

04-2003

-5-

Thank you for purchasing a Savaria product. The Savaria team hopes you will enjoy your new B.07 stairlift. If you have any trouble during it's use, do not hesitate to call us at 450-681-5655 or at our toll free number : 1-800-931-5655 and we will be pleased to help.

If you have any comments or suggestions, please fax us at (450) 681-4745 or send us an e mail at savaria@savaria.com.

Sébastien Bourassa
Stairlift Technician

HOW CONNECT THE TRAVELING CABLE, BATTERIES AND INFRA-RED RECEIVERS ON THE B.07 G

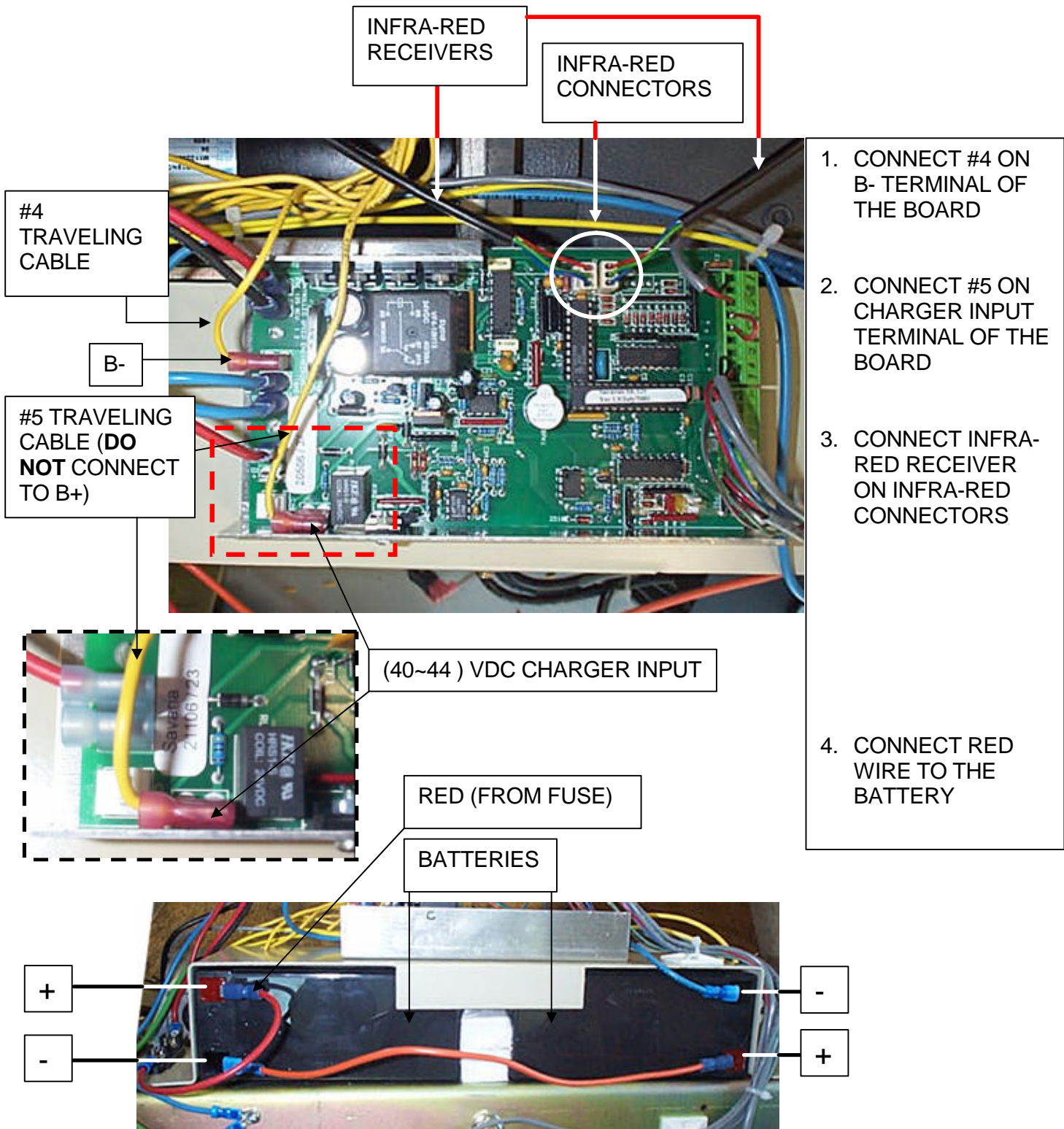

Operation of the lift when fitted with the CSE125

Precautions when working on the CSE125 board and lift

When working on a lift *always disconnect the charge transformer from the mains* and only reconnect when the lift is fully working.

The board is sensitive to static charge. To avoid damage, touch a metal surface on the lift to discharge yourself of static charge but do not touch the IC chips.

Please handle the board with care.

Do make sure you double check the connections to the motor and battery before switching on.

Power up delay

When the board is first powered there is a 3 second delay. If either the UP/DOWN controls are enabled the lift will not move until the command is removed, then the lift will work. This is a safety feature, it stops the lift moving 0.5 seconds after the power is applied and the UP/Down controls are enabled.

Lift control and operation delay

The lift is operated by pressing the UP/DOWN control, it will bleep then 0.5 seconds later it will start off. If a change of direction is initiated while running, the lift will take 3 seconds to restart after it has stopped.

Charger alarm and Battery capacity indication

The board is fitted with LEDs and a bleeper to indicate various functions or faults.

Bleeping when the lift stops -

The lift, on reaching an end stop, will check that the battery charger supply is switched on. If not is not switched on, it will sound its' bleeper for 20 seconds. After the 20 seconds, the bleeper will stop.

Extended bleep when the lift starts -

The capacity of the batteries has reduced to 30%. This has occurred because of the following reasons

1. Batteries have not been charged.
2. Heavy use of the lift.
3. The batteries are not holding their charge due to age.
4. A cell has become damaged due to age.

Lift running at half speed

The capacity of the batteries has reduced to 10%. See above.

LED indication

Note - The red and the yellow leads are on the board.

Red LED on or flashing

When the connection between pins 1 and 3 are broken (safety circuit) swivel seat switch is activated, slack chain switch is activated, motor thermo-switch on or final limit is activated, the red LED will come on. When the red LED is on, the lift will not go.

The UP/DOWN command will be ignored.

The reason for it flashing is because the charger has not been connected.

Yellow LED indicates the following fault -

The yellow LED indicates low volts. The battery volts are less than 21V when the battery is first connected. When the battery has been connected the minimum voltage is 16.5 volts.

The flashing yellow LED indicates a fault which is:

1. Relay fault. Each time the lift starts or stops the main power relay is checked to ensure that the contacts have not welded together. If the fault persists then replace the board.

Setting transmitter codes

Ensure the lift is working and the IR receivers are connected.

Refer to wiring diagram for CSE125.

Take the back off the transmitters, set them to the same code. Press the red push button on the CSE125 (PB1) and push the UP or DOWN on the transmitter. Now stop pressing the red button on the CSE125 board, the lift should bleep and start moving. If the lift is at one of the end stops, you may find that the lift does not bleep when you stop pressing the red button on the CSE125 board, if this is the case then press the other button on the transmitter.

Common problems

Q. The lift does not move and no LED indication, but the power is connected

A. Ensure the seat is set correctly, if there is still no LED indication, check final limit (has the lift ran on ?). If there is still no indication, switch the board off. Wait two seconds then power up. Four seconds later there will be a bleep, if not the board may be faulty.

Check battery volts on the B+ and B- terminals of the board. If there is power, check for battery volts on pin 1 of the control connector (pin 1 is the pin nearest the corner of the board opposite side to PB1). Refer to drawing.

If there are no battery volts on pin 1 of the connector, pull both the connector blocks and wait for approximately 5 seconds. The board should then bleep and the red LED on the board should come on. If not replace the board.

If the board bleeps there will be a short circuit somewhere.

To check for short circuits, disconnect the battery and test between B- and the control wiring.

Q. The red LED is on.

A. The lift will not move because the seat swivel/ normal limit switch is not in the correct position, also check the slack cable and final limit. Safety circuit is open circuit.

Q. The yellow LED is on.

A. The lift will not move because the battery volts are less than 21V when the batteries were first connected or have fallen below 16.5 volts when the lift was running. Ensure the charger supply is connected and the charger is working (see general notes).

Q. The remote controls operate intermittently.

A. Check the batteries in the transmitters.
If only one transmitter is responsible for the fault, replace that transmitter (it is probably a faulty button). If both transmitters are causing problems, check the receivers or the board.

Q. The lift bleeps continuously.

A. Check for a smoke alarm (low battery indication) or burglar alarm. The CSE125 does not bleep continuously, it will only bleep for 20 seconds .

General Notes

Always replace the batteries in pairs. *Do not mix* old and new batteries in the same lift.

To test the battery charger:

Measure the battery voltage with your meter, momentarily press either the up or down button on the remote control, the lift will bleep. The battery volts will dip down, then increase back to the original measured voltage. If this happens the charger is working.

Changing Channels

To reset the control channel follow this procedure:-

1. Disconnect battery.
2. If possible disconnect the battery charger, if this is not possible remember the board is still partially live and proceed with caution.
3. Take the cover off the carriage giving access to the CSE125 control board. Make sure one of the IR. receivers is connected to the control board.
4. Reconnect battery. Note the red button situated by the connectors
5. Take the back off the remote transmitter, inside is a small blue DIL switch set to 1 up and 2 down as below.

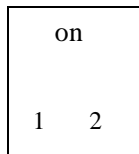

Select another number, say 1 down 2 down.

6. Press the red button on the remote if the lift is at the bottom, or green button if at the top.
7. Press the red button on the control board, release the button. There will be a bleep and the lift will move off. The new channel has now been selected.
8. Make sure both transmitters are programmed to the same channel. Fit back covers etc.

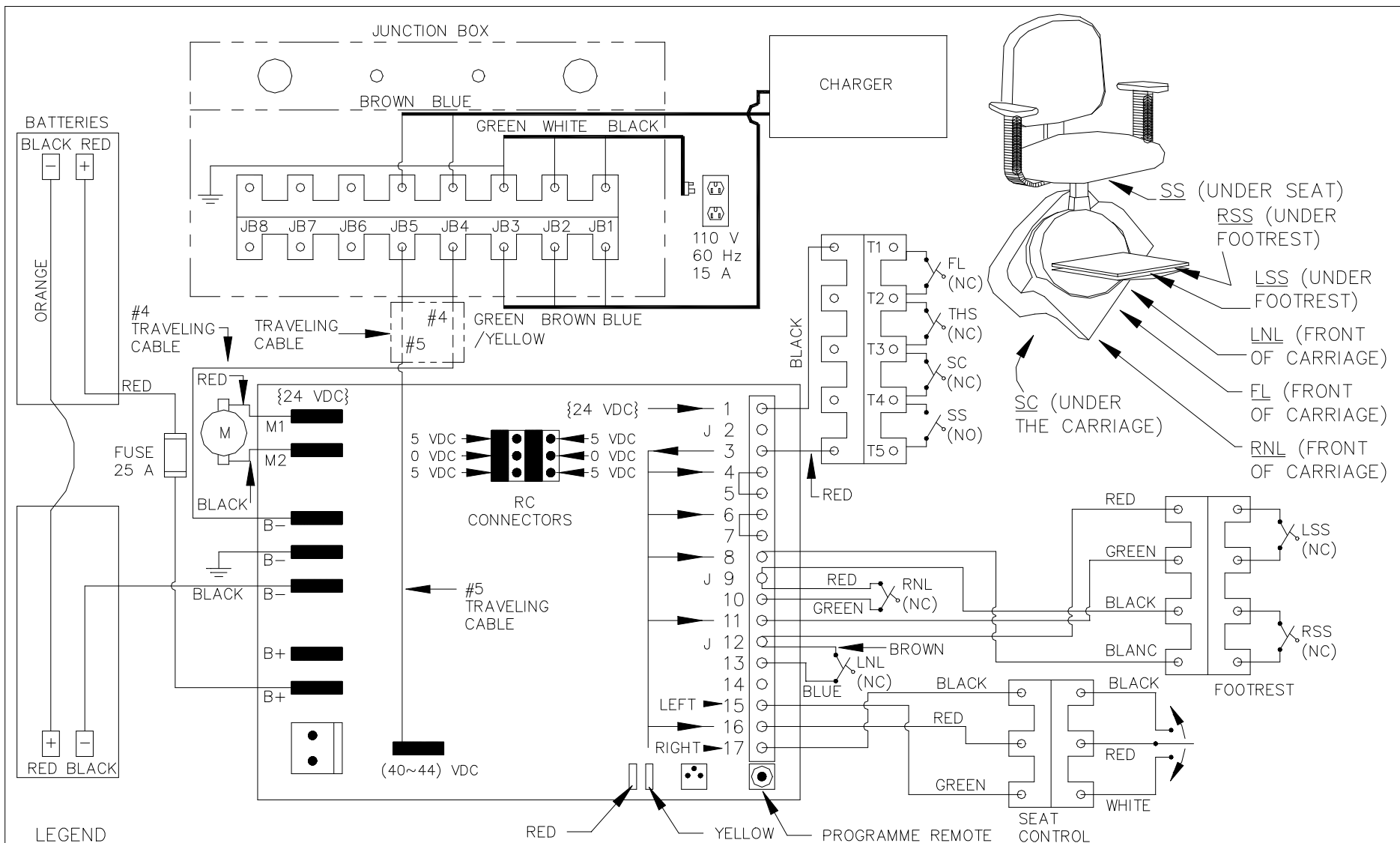

LEGEND

- B = TERMINAL (+ OR -)
- FL = FINAL LIMIT
- J = TERMINAL AVAILABLE FOR JUNCTION
- JB# = PLUG IN # (LOCATED ON JUNCTION BOX)
- LNL = LEFT NORMAL LIMIT
- LSS = LEFT SAFETY SWITCH
- LT = LEFT TRAVELLING
- M = MOTOR

- RC = REMOTE CONTROL
- RNL = RIGHT NORMAL LIMIT
- RSS = RIGHT SAFETY SWITCH
- RT = RIGHT TRAVELLING
- SC = SLACK CHAIN SWITCH
- SS = SWIVEL SEAT CUT-OFF SWITCH
- T# = PLUG IN # (LOCATED ON CARRIAGE)
- THS = MOTOR THERMO-SWITCH

MODEL: B.07 G		QTY.:	
TOLERANCES IF NOT SPECIFIED			
DEC:	ANG:		
SCALE:	DRAWN BY:	NO.	REVISIONS
	S.ARÈS		DATE
MATERIAL:	DATE:	SERVICES INDUSTRIELS SAVARIA INC.	
	2001/08/10		
DRAWING #	REV#	PAGE:	TITRE:
SG-ELECT	0	1/1	ELECTRIC DIAGRAM WITH TRAVELING CABLE

Troubleshooting procedure CSE 125 B.07G

