



# P.A.L.™

VERTICAL PLATFORM LIFT

## Planning Guide (Imperial)

For Vertical Platform Lifts

P.A.L. - S (Unenclosed or Hoistway Models)

P.A.L. - EN (Fully Enclosed Models)

### **Applicable Codes:**

ASME A18.1

CAN/CSA B355

Effective May 1<sup>st</sup>, 2006

Revised September 1<sup>st</sup>, 2006

Revised April 7<sup>th</sup>, 2007

Revised October 17, 2008



# Table of Contents

<b>GENERAL</b>	<b>2</b>
<b>PRODUCT DESCRIPTION</b>	<b>3</b>
<b>P.A.L. - S VERTICAL PLATFORM LIFT SPECIFICATIONS</b>	<b>5</b>
<b>CAB TYPE SELECTION SHEET</b>	<b>6</b>
<b>MODEL AND TRAVEL OPTIONS</b>	<b>7</b>
<b>P.A.L. - S OVERVIEW</b>	<b>8</b>
<b>P.A.L. - EN OVERVIEW</b>	<b>9</b>
<b>P.A.L. FOOTPRINT LAYOUT</b>	<b>10</b>
<b>P.A.L. IN A HOISTWAY WITH UPPER LANDING PRO/P.A.L. DOOR</b>	<b>11</b>
<b>P.A.L. IN A HOISTWAY WITH UPPER LANDING GATE</b>	<b>12</b>
<b>P.A.L. TYPE 1L 36" x (48" OR 54" OR 60") HOISTWAY APPLICATION - PLAN VIEW</b>	<b>13</b>
<b>P.A.L. TYPE 1L 42" x 60" HOISTWAY APPLICATION - PLAN VIEW</b>	<b>14</b>
<b>P.A.L. TYPE 2L 36" x (48" OR 54" OR 60") HOISTWAY APPLICATION - PLAN VIEW</b>	<b>15</b>
<b>P.A.L. TYPE 2L 42" x 60" HOISTWAY APPLICATION - PLAN VIEW</b>	<b>16</b>
<b>P.A.L. TYPE 3 (OR 4) 42" x 60" HOISTWAY APPLICATION - PLAN VIEW</b>	<b>17</b>
<b>P.A.L. ENCLOSURE WITH 43 3/8" UPPER LANDING GATE - ELEVATION VIEW</b>	<b>18</b>
<b>P.A.L. ENCLOSURE WITH UPPER LANDING P.A.L. DOOR AND DOME TOP - ELEVATION VIEW</b>	<b>19</b>
<b>P.A.L. TYPE 1L 36" x (48" OR 54" OR 60") ENCLOSURE APPLICATION - PLAN VIEW</b>	<b>20</b>
<b>P.A.L. TYPE 1L 42" x 60" ENCLOSURE APPLICATION - PLAN VIEW</b>	<b>21</b>
<b>P.A.L. TYPE 2L 36" x (48" OR 54" OR 60") ENCLOSURE APPLICATION - PLAN VIEW</b>	<b>22</b>
<b>P.A.L. TYPE 2L 42" x 60" ENCLOSURE APPLICATION - PLAN VIEW</b>	<b>23</b>
<b>P.A.L. TYPE 3 (OR 4) 42" x 60" ENCLOSURE APPLICATION - PLAN VIEW</b>	<b>24</b>
<b>PRO AUTO AND PRO MANUAL DOOR SPECIFICATIONS</b>	<b>25</b>
<b>P.A.L. - S (STANDARD) NOTES</b>	<b>26</b>
<b>P.A.L. - EN (ENCLOSURE) NOTES</b>	<b>27</b>
<b>SPECIFICATIONS FOR A18.1/B355 COMPLIANCE</b>	<b>28</b>

# General

This Planning Guide is designed to assist architects, contractors, building owners and lift professionals in planning for a P.A.L. Vertical Platform Lift that meets the requirements of ASME A18.1 & CSA B355.

This unique lift is designed to help solve accessibility problems in commercial and residential buildings while meeting state and national codes covering vertical platform lifts.

We strongly recommend you contact the Authority Having Jurisdiction (AHJ) in the region where the equipment will be installed. Become familiar with all requirements governing the installation and use of lifts in public and private buildings. It is extremely important for you to know and adhere to all regulations concerning installation and use of lifts.

## IMPORTANT NOTICE

This Planning Guide provides dimensions and specifications useful for the INITIAL planning of a wheelchair lift project. Before beginning actual construction, be sure to receive application drawings customized to suit the specifications and dimensions for your specific project.

Call 1-800-661-5112 for a Savaria Concord Dealer in your area.

Wheelchair lift configurations and dimensions are in accordance with Savaria Concord Lifts Inc. interpretation of the standards set forth by ASME A18.1 & CSA B355. Please consult Savaria Concord Lifts Inc. or the P.A.L. dealer in your area for more specific information pertaining to your project, including any deviation between referenced standards and those of any local AHJ. The dimensions and specifications in this Planning Guide are subject to change (without notice) due to product enhancements and continually evolving codes and product applications.

### **Steps of planning for a P.A.L. Vertical Platform Lift from Savaria Concord Lifts Inc. :**

1. Determine customer's intention for use
2. Determine code requirements of site
3. Determine installation parameters of site
4. Determine the car type from the hoistway/enclosure requirement pages
5. Determine the interior size of the car
6. Use the appropriate chart to determine the hoistway requirements
7. Use page 25 to plan for hoistway door requirements
8. Use page 26 to plan for electrical requirements

# Product Description

## What is a Vertical Platform Lift?

A vertical platform lift transports a passenger, in a wheelchair or someone who has difficulty using stairs from one landing to another. Vertical platform lifts provide a code compliant access solution for lifting heights of up to 12 ft (in some jurisdictions lifts can travel up to 14 ft). A vertical platform lift can be operated independently or by an attendant. The Savaria Concord P.A.L. vertical platform lift is versatile, attractive and suitable for indoor or outdoor applications.

## Why Choose a Vertical Platform Lift?

### Cost-effective

Vertical lifts are more cost-effective than an elevator and can be used outdoors, plus they do not require a machine room to house the electrical and mechanical components.

### Blends with the Environment

A vertical lift can be an attractive alternative and take less space than a lengthy ramp. Adjacent to stairs or in an area complementary to your building, these lifts can be blended or finished to compliment the aesthetics of the site.

### Meets (ADA) Americans with Disabilities Act Requirements

Savaria Concord vertical platform lifts meet the requirements of the ADA Accessibility Guidelines as a means to provide public building access.

### Design Assistance

With over 30 years of experience, Savaria Concord Lifts Inc. has the expertise to provide solutions to practically every design challenge you face. Please call our Customer Service Department for professional advice at (800)661-5112 or (905)791-5555.

### Custom Finishes

The standard finish on all Savaria Concord Lifts Inc. products is electrostatically applied baked powder enamel finish in Architectural White. These components can also be powder coated with several optional colors or any custom color available. The Savaria Concord enclosure is constructed from an aluminum frame and can be supplied with  $\frac{3}{16}$ " bronze tinted or clear Plexiglass panels or  $\frac{1}{4}$ " tempered glass or laminated safety glass panels.

### Outdoor Applications

When located outdoors, The Savaria Concord P.A.L. is the only lift available with standard stainless steel to prevent corrosion. This ensures the ultimate durability and reliable performance above any other product in the industry. Conformal coated circuit boards and a NEMA 3R rated control enclosure allows for outdoor installations in extreme climates, and work great in certain indoor applications such as near swimming pools.

## Product Description (cont'd)

### How it Works

The P.A.L. vertical platform lift is offered in a variety of configurations and styles for different accessibility challenges. All versions of the P.A.L. vertical lift operate in the same manner. They consist of a complete drive system, a platform with side walls plus optional doors with interlocks and call stations.

The mast houses the mechanical components that raises and lowers the cantilevered platform while a 3RNEMA rated control box houses the electrical and electronic components. The doors or gates can not be opened unless the platform is at the appropriate landing. The platform is called to the landing by using the call stations located at each landing. When a passenger is on the lift, the platform controls override the call stations. Once at a landing, the door interlock is released and the door can be opened to exit.

The P.A.L. can be used to provide access indoors or outdoors and can be installed directly on the floor with a ramp or in a 3" deep pit.

### Model Availability

The P.A.L. is available in three styles: the Enclosure Model, the Hoistway Model and the Unenclosed Model. The Enclosure Model consists of a mast, platform, doors and the walls that enclose the lift. The Hoistway Model consists of a mast, platform and doors. The walls enclosing the hoistway unit are built by others in accordance to Savaria Concord's specifications. The Unenclosed Model consists of a mast & platform with optional platform gate and landing gate

### Enclosure Model

The enclosure frame is constructed of architectural white aluminum extrusions. The attractive softline corner posts enhance the appearance of the lift. Due to the unique design of the corner posts, the nuts, bolts and screws are hidden providing a professional installation. Horizontal cross members are fitted into the corner posts strengthening the structure. The panels come in a choice of 16 gauge painted galvanized mild steel,  $\frac{3}{16}$ " bronze tinted or clear Plexiglass or  $\frac{1}{4}$ " tempered or safety laminated glass.

### Hoistway Model

The P.A.L. Hoistway unit is designed to fit the essential lift components within your hoistway walls. The P.A.L. Hoistway Model can have either aluminum frame doors/gates, fire rated pro-manual (or auto) doors, or the doors can be supplied by others. All styles of doors/gates have interlocks integrated with the onboard control system.

### Unenclosed Model

The P.A.L. Unenclosed Model is designed for applications where enclosures or hoistways are not required and is limited to travel heights of 72". The P.A.L. Unenclosed Model can have either aluminum frame gates mounted on the platform or upper landing. All styles of gates have interlocks integrated with the onboard control system.

## P.A.L. - S Vertical Platform Lift Specifications

Load Capacity	750 lbs.
Rated Speed	15 fpm
Power Supply (circuit to be supplied by others)	North American: 115 volt, 60 Hz, 15 amps / International: 220 volt, 50 Hz, 10 amps
Drive System	1:2 Cable Hydraulic w/ Slack Cable Safety Device 1 hp 24 Volt DC motor 0.69 gpm, max 2300 psi Two 3/8" diameter steel aircraft cables Rope wedge sockets Valve assembly
Cab Size	36" x 48", Type 2 (standard) 36" x 54", Type 1, 2, 3, 4 36" x 60", Type 1, 2, 3, 4 42" x 60", Type 3, 4 1100 mm x 1400 mm (UK), Type 1, 2, 3, 4
Lifting Height	Standard 48" Floor to Floor Available 72", 96", 120", 144", 168" Floor to Floor
Control System	Constant Pressure User Interface Solid State Electronics with Relay Logic Motor Controls
Lift Finish	Stainless Steel Tower and Mechanical Assembly w/ Baked Electrostatic Polyester Gloss Powder
Hall Station Finish	Mylar Membrane
Standard Features	43 3/8" High Aluminum Framed Cab Walls Automatic Emergency Platform Lighting Battery Back-Up allowing for Travel in both Up and Down Directions Cab Operating Panel with Illuminated Buttons Data Plates, Capacity Tags and Rope Tags Emergency Manual Lowering Device Emergency Battery Back-up for Lighting, Alarm and Raising/Lowering Keyed Manual Lowering Device Limited Warranty covers the repair or replacement of any defective parts for a period of 36 months from date of shipment Maintenance Pit Props Manual Reset Slack Rope Safety Switch Pit Switch Presentation Drawings Stainless Steel Platform with applied Anti-Skid Flooring Stainless Steel Handrail Two 12 V, 33 AH, Sealed No Maintenance Batteries with 24 V, 3.3 amp Smart Charge™ Battery Charge Upper and Lower Terminal Limits
Options	16" Automatic Flip Up Entrance Ramp Automatic Gate and Door Opener Bottom Floor Permanent Ramp (8:1 or 12:1) Dome or Slope Roof (EN models only) Emergency Hands-Free Telephone Force Ventilation System (EN models only) Freestanding or Wall Mount Enclosure Keyed ON/OFF Control Panel and Hall Stations Motion Sensor Lighting (EN models only) Pro Manual or Pro Auto Fire Rated Door with Prolocks Underpan Safety Sensor (standard where required by Code)

The Savaria Concord P.A.L. meets the requirements of ASME A18.1/CSA B-355 for a Vertical Platform Lift.

# Cab Type Selection Sheet

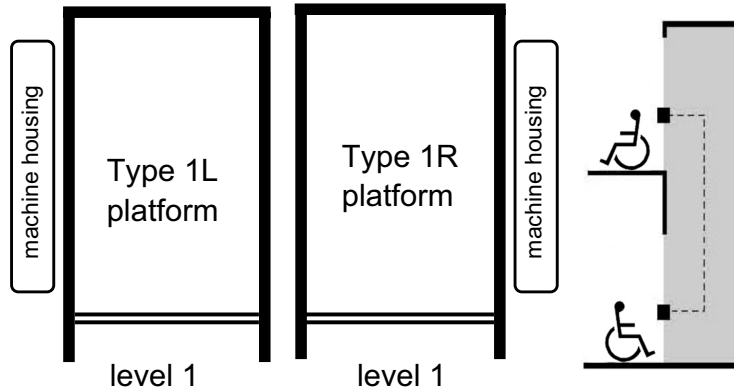

**All Types - The location (L or R) of the Machine Housing when the lift is at the bottom landing determines the handing or type of the lift.**

## Type 1 Cabs

Floor 1 to Floor 2 travel must be a minimum of 96".

Entry and Exit are available from only one end of the platform.

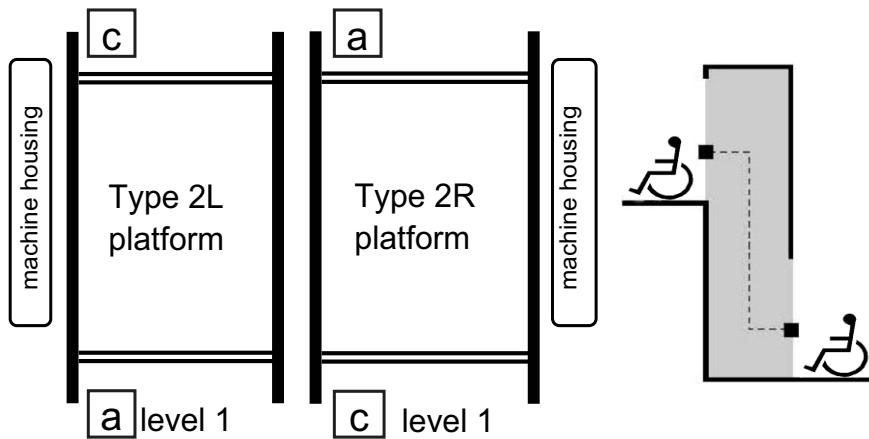

## Type 2 Cabs

Floor to Floor travel must be a minimum of 8".

Entry and Exit are available from both ends of the platform.

This platform type is standard as it is the most user friendly design for wheelchair access.

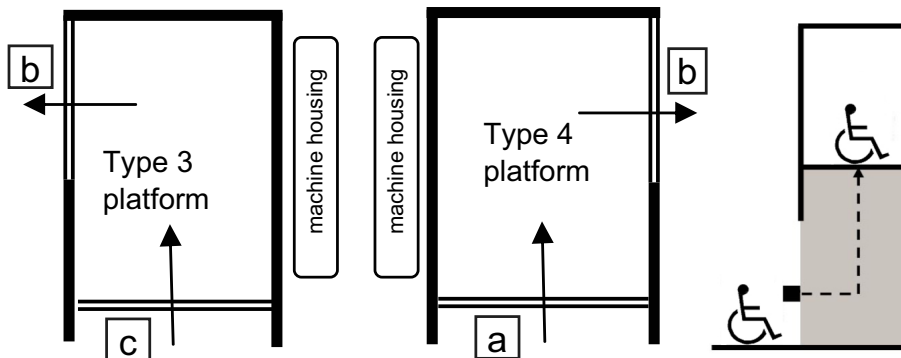

## Type 3 and 4 Cabs

Floor to Floor travel must be a minimum of 8".

Entry and Exit are available from only one end and one side of the platform.

These cabs are for applications where it is necessary to position the lift for straight entry at the bottom level and exit at 90 degrees at the top landing.

# Model and Travel Options

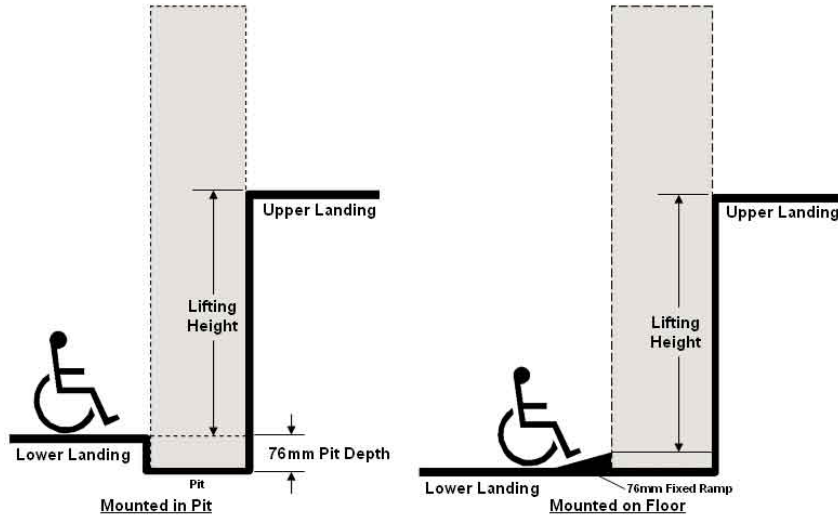

## NOTE

The 'Lifting Height' (Maximum Travel) is the vertical distance between the upper landing and the lower entrance level. If the lift is not mounted in a Pit, a ramp is required.

### Table 1 - Mast Height

Models	Maximum Travel (3" pit)	Mast Height (Private)	Mast Height (Public)
48"	35 <sup>5</sup> / <sub>8</sub> "	81"	81"
48"	35 <sup>3</sup> / <sub>4</sub> " - 48"	81"	105"
72"	48 <sup>1</sup> / <sub>8</sub> " - 59 <sup>5</sup> / <sub>8</sub> "	105"	105"
72"	59 <sup>3</sup> / <sub>4</sub> " - 72"	105"	129"
96"	72 <sup>1</sup> / <sub>8</sub> " - 83 <sup>5</sup> / <sub>8</sub> "	129"	129"
96"	83 <sup>3</sup> / <sub>4</sub> " - 96"	129"	153"
120"	96 <sup>1</sup> / <sub>8</sub> " - 107 <sup>5</sup> / <sub>8</sub> "	153"	153"
120"	107 <sup>3</sup> / <sub>4</sub> " - 120"	153"	177"
144"	120 <sup>1</sup> / <sub>8</sub> " - 131 <sup>5</sup> / <sub>8</sub> "	177"	177"
144"	131 <sup>3</sup> / <sub>4</sub> " - 144"	177"	201"
168"	144 <sup>1</sup> / <sub>8</sub> " - 155 <sup>5</sup> / <sub>8</sub> "	201"	201"
168"	155 <sup>3</sup> / <sub>4</sub> " - 168"	201"	225"

Model availability varies depending on the cab type ordered.

### Table 2 - Elevation of Mast Attachment Points

Mast Height	81"	105"	129"	153"	177"	201"	225"
Mandatory Wall Mounting	75 <sup>1</sup> / <sub>2</sub> "	75 <sup>1</sup> / <sub>2</sub> "	75 <sup>1</sup> / <sub>2</sub> "	75 <sup>1</sup> / <sub>2</sub> "	75 <sup>1</sup> / <sub>2</sub> "	75 <sup>1</sup> / <sub>2</sub> "	75 <sup>1</sup> / <sub>2</sub> "
	N/A	100"	123 <sup>7</sup> / <sub>8</sub> "	119 <sup>3</sup> / <sub>4</sub> "	123 <sup>7</sup> / <sub>8</sub> "	123 <sup>7</sup> / <sub>8</sub> "	119 <sup>3</sup> / <sub>4</sub> "
	N/A	N/A	N/A	147 <sup>3</sup> / <sub>4</sub> "	171 <sup>7</sup> / <sub>8</sub> "	167 <sup>3</sup> / <sub>4</sub> "	147 <sup>3</sup> / <sub>4</sub> "
	N/A	N/A	N/A	N/A	N/A	195 <sup>3</sup> / <sub>4</sub> "	191 <sup>7</sup> / <sub>8</sub> "
	N/A	N/A	N/A	N/A	N/A	N/A	219 <sup>7</sup> / <sub>8</sub> "

# P.A.L. - S Overview

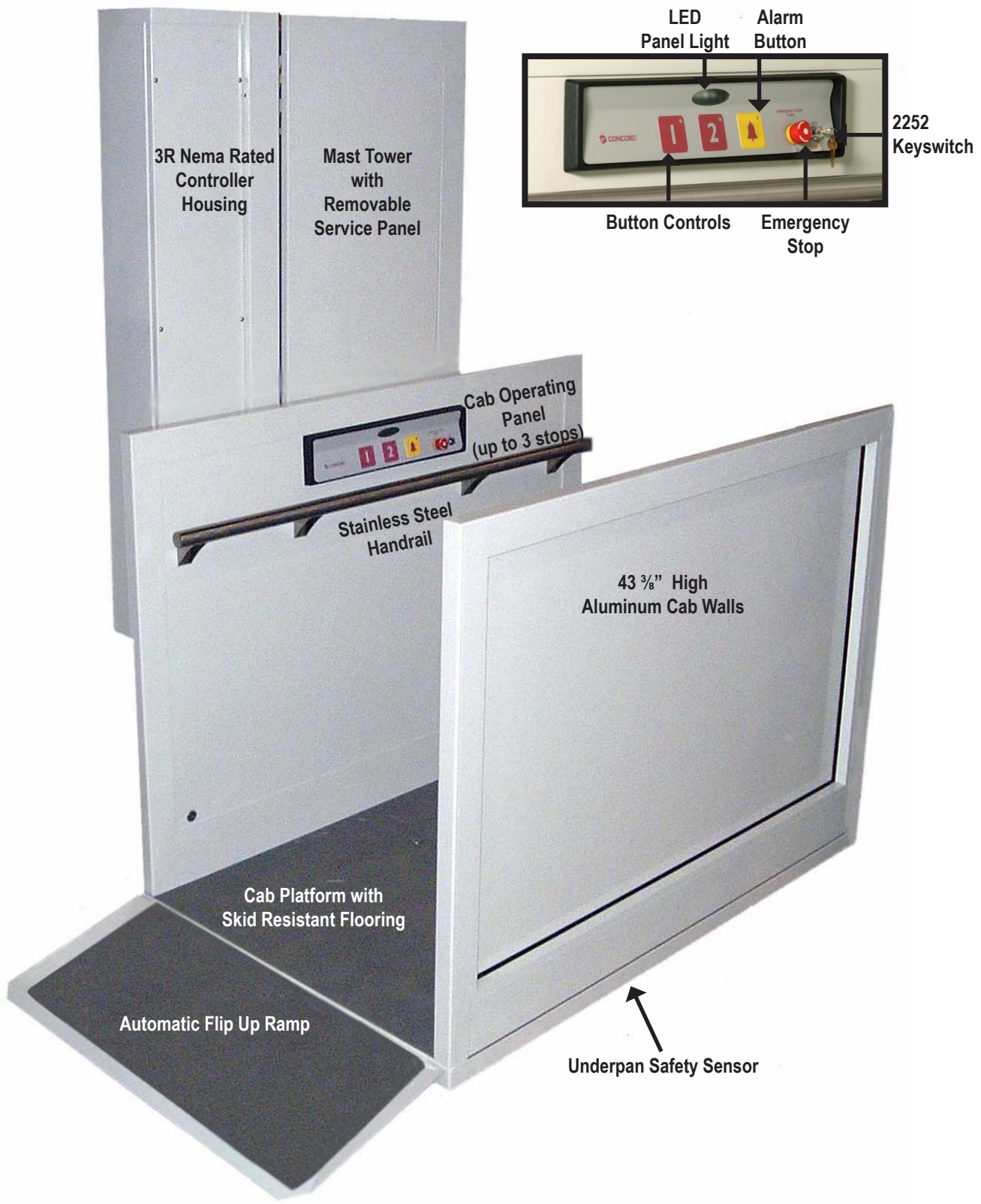



# P.A.L. FOOTPRINT LAYOUT

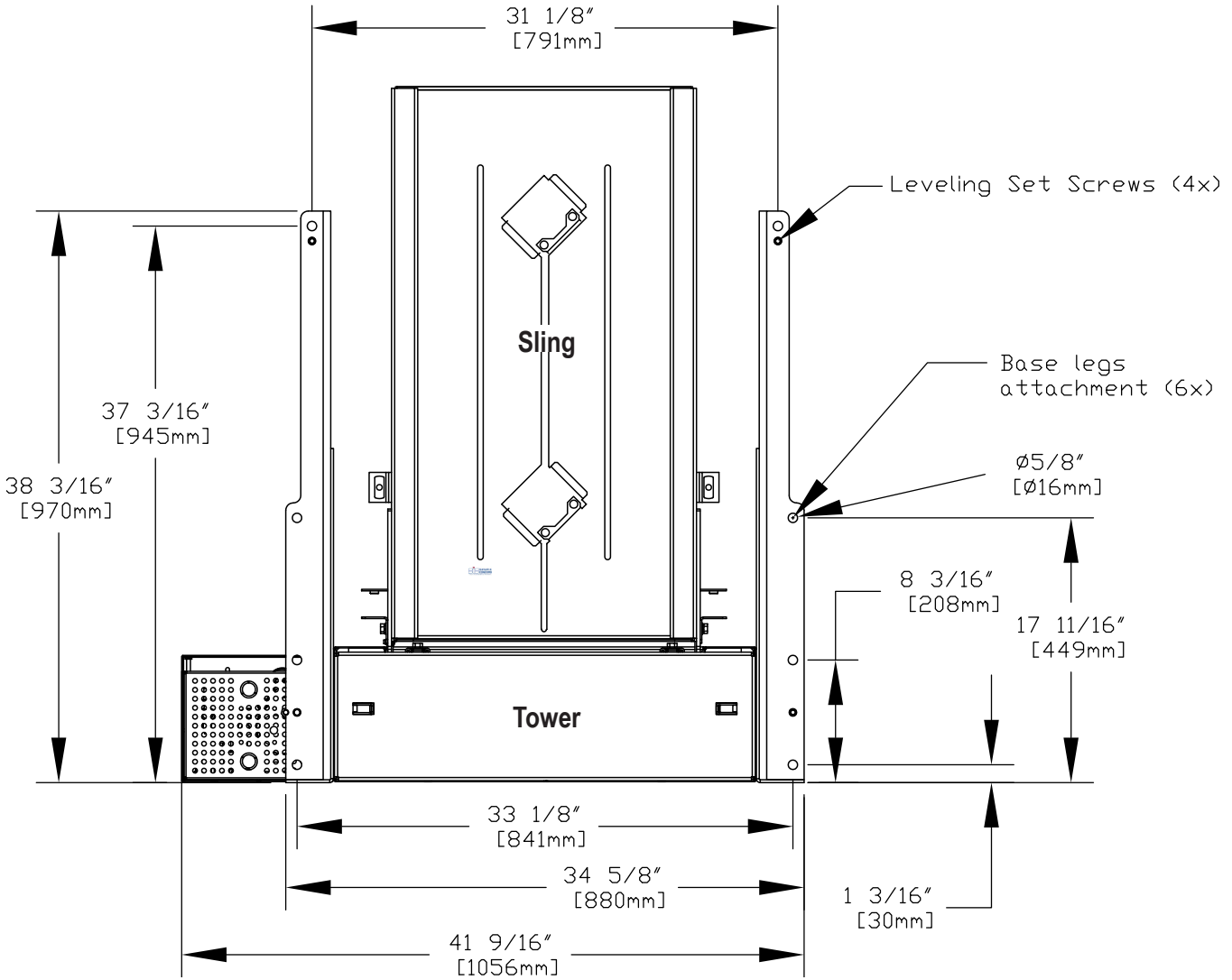

**P.A.L. IN A HOISTWAY WITH UPPER LANDING PRO/P.A.L. DOOR  
ELEVATION VIEW OF TYPE 2 SHOWN, TYPE 1, 3 AND 4 AVAILABLE**

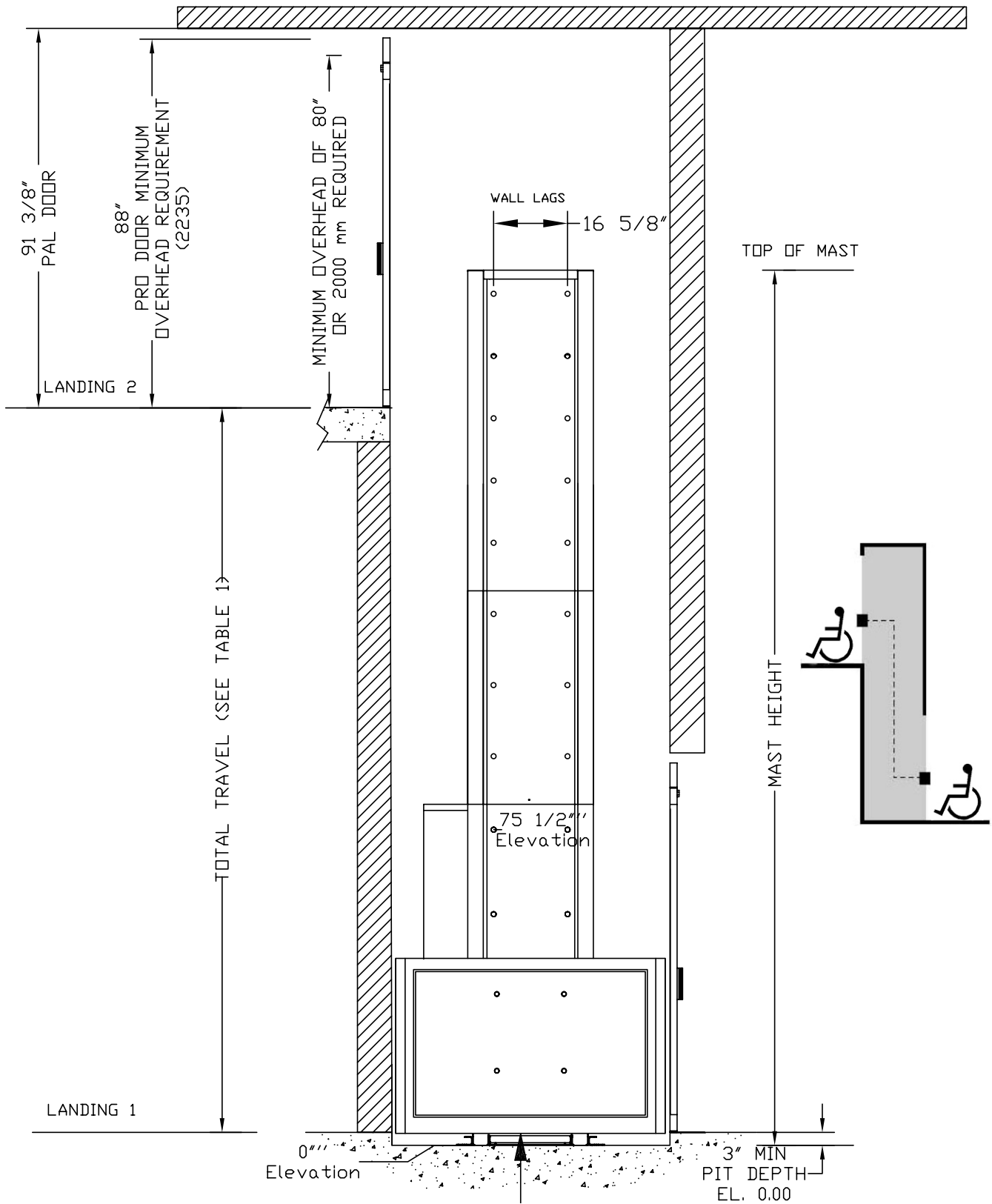

**NOTE**

Door and Gate overhead clearances do not include automatic door and gate operators. Custom drawings must be generated to include these options.

**P.A.L. IN A HOISTWAY WITH UPPER LANDING GATE  
ELEVATION VIEW OF TYPE 2 SHOWN, TYPE 1, 3 AND 4 AVAILABLE**

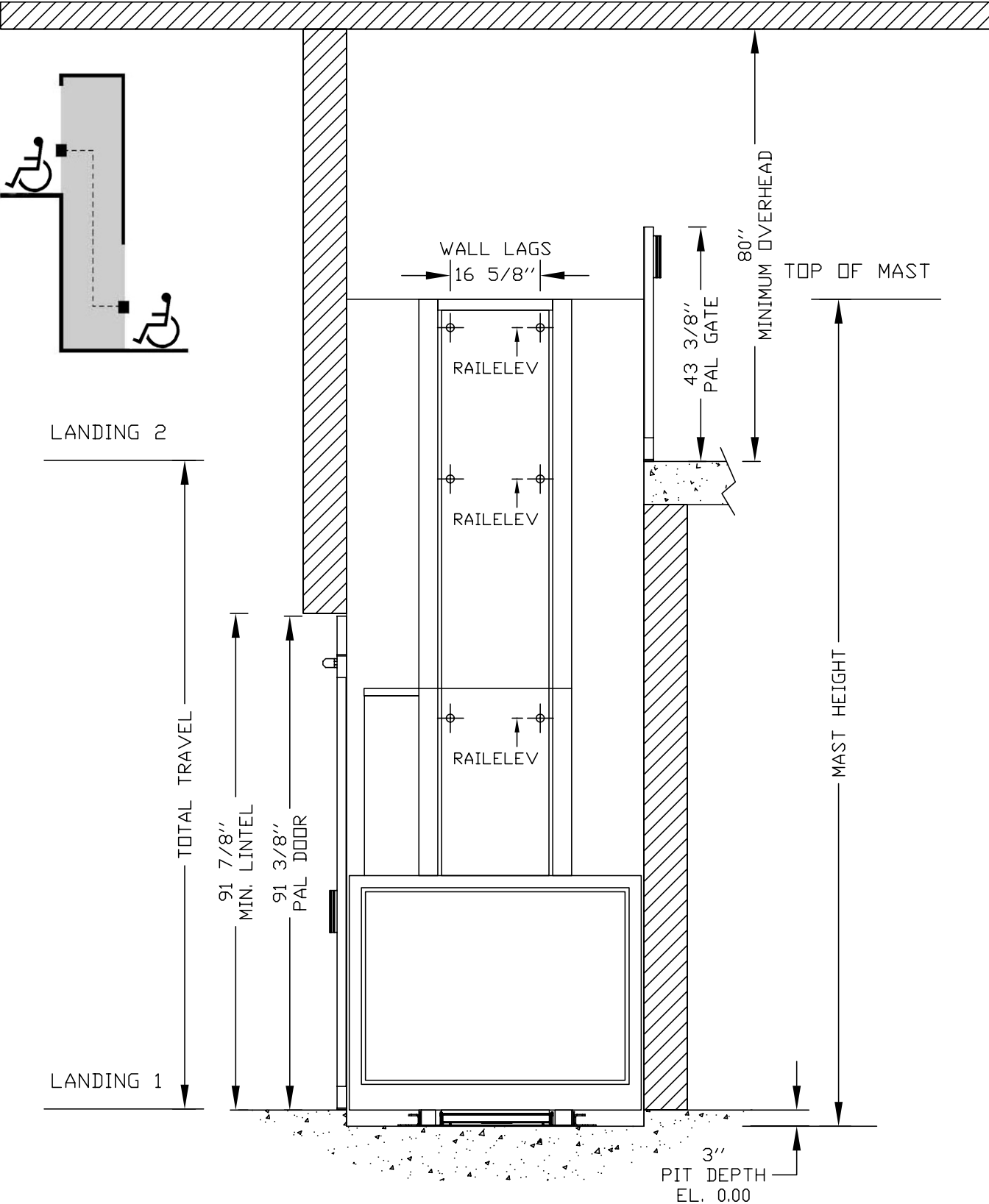

**NOTE**

Door and Gate overhead clearances do not include automatic door and gate operators. Custom drawings must be generated to include these options.

# P.A.L. TYPE 1L 36" x (48" OR 54" OR 60") HOISTWAY APPLICATION - PLAN VIEW

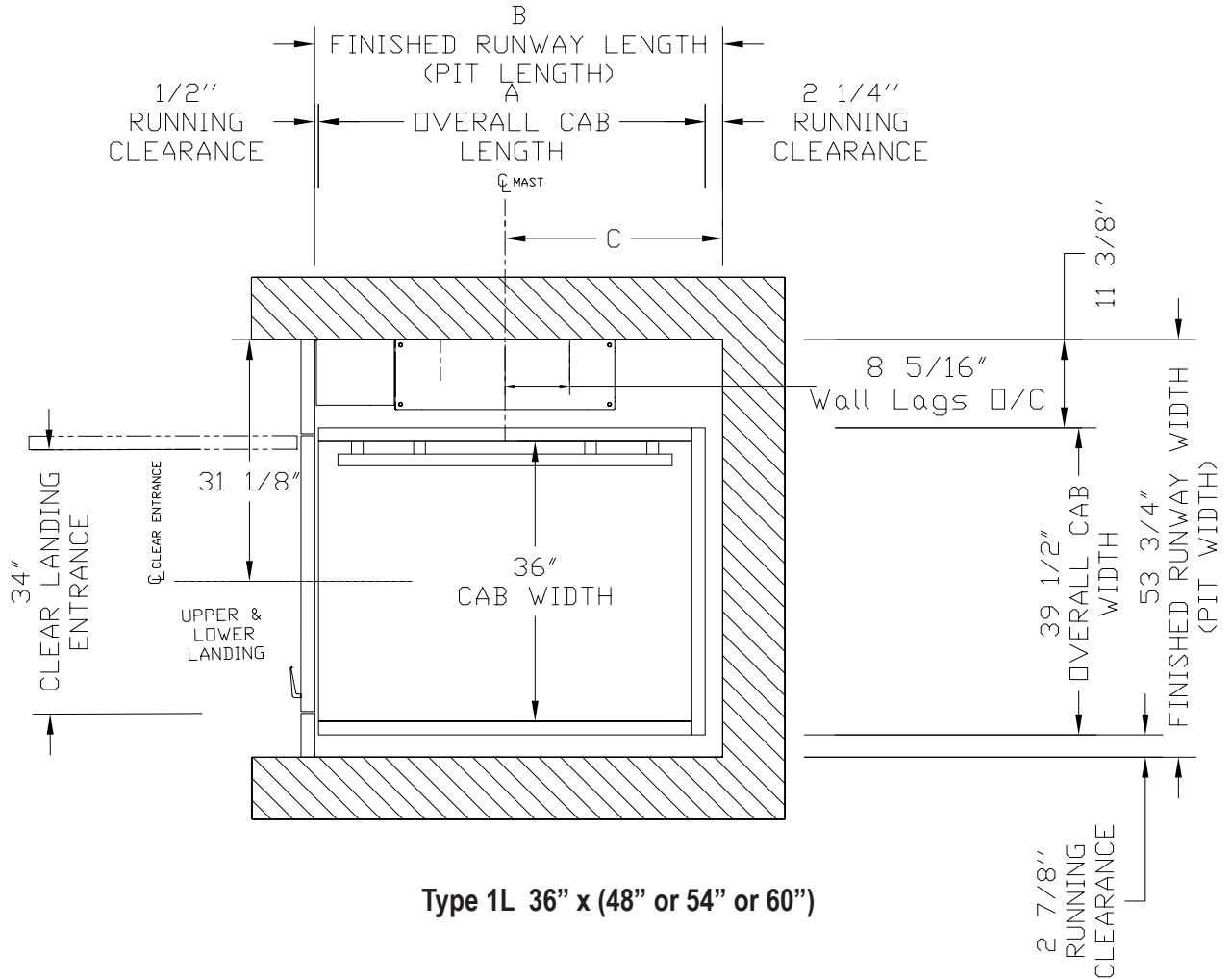

Type 1L 36" x (48" or 54" or 60")

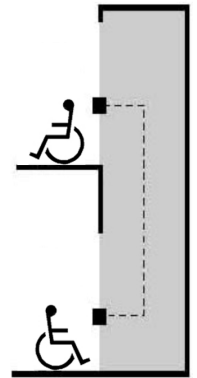
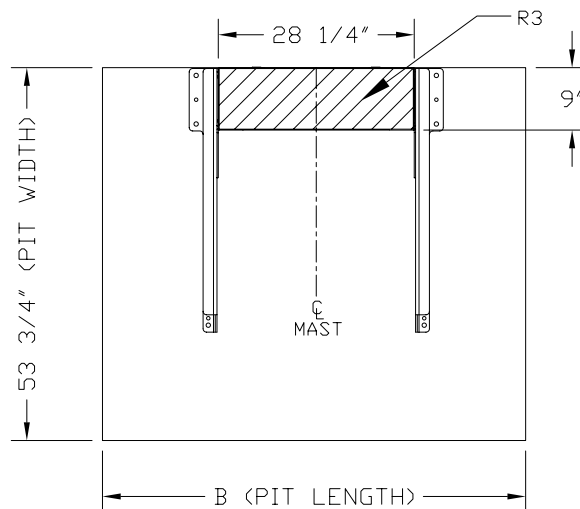

Clear Inside Cab Width	Clear Inside Cab Length	Dimension A	Dimension B	Dimension C
36"	48"	49 3/4"	52 1/2"	28"
36"	54"	55 3/4"	58 1/2"	31"
36"	60"	61 3/4"	64 1/2"	34"

**PLAN DRAWING CAN BE REVERSED FOR RIGHT HAND CONFIGURATIONS.**

# P.A.L. TYPE 1L 42" x 60" HOISTWAY APPLICATION - PLAN VIEW

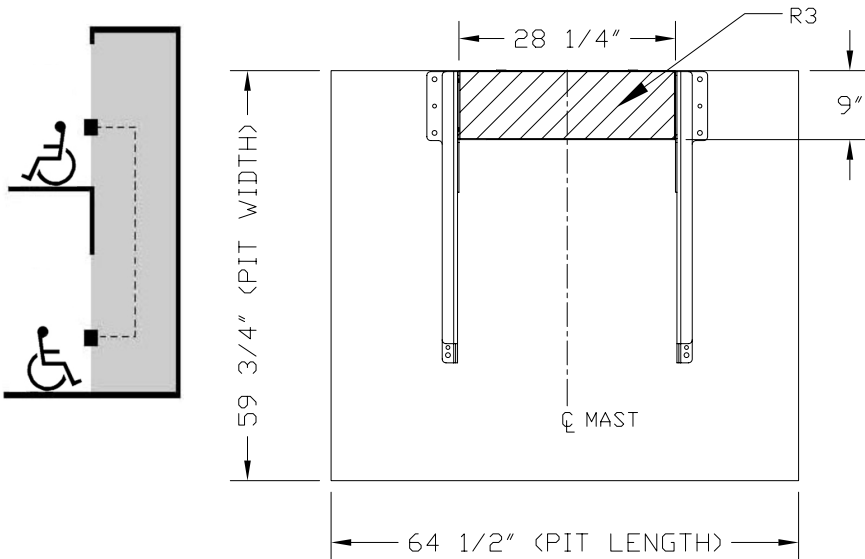
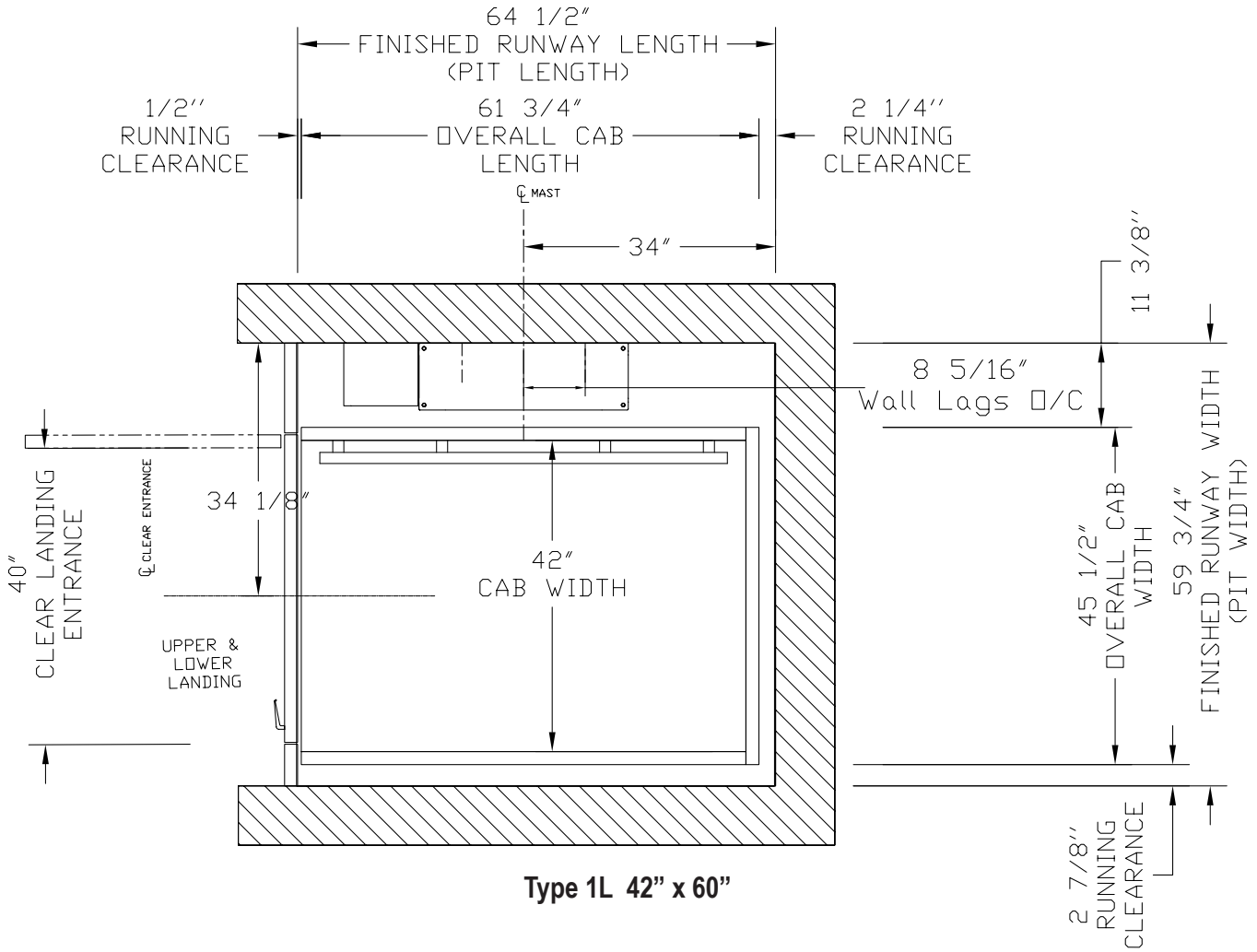

PLAN DRAWING CAN BE REVERSED FOR RIGHT HAND CONFIGURATIONS.

# P.A.L. TYPE 2L 36" x (48" or 54" or 60") HOISTWAY APPLICATION - PLAN VIEW

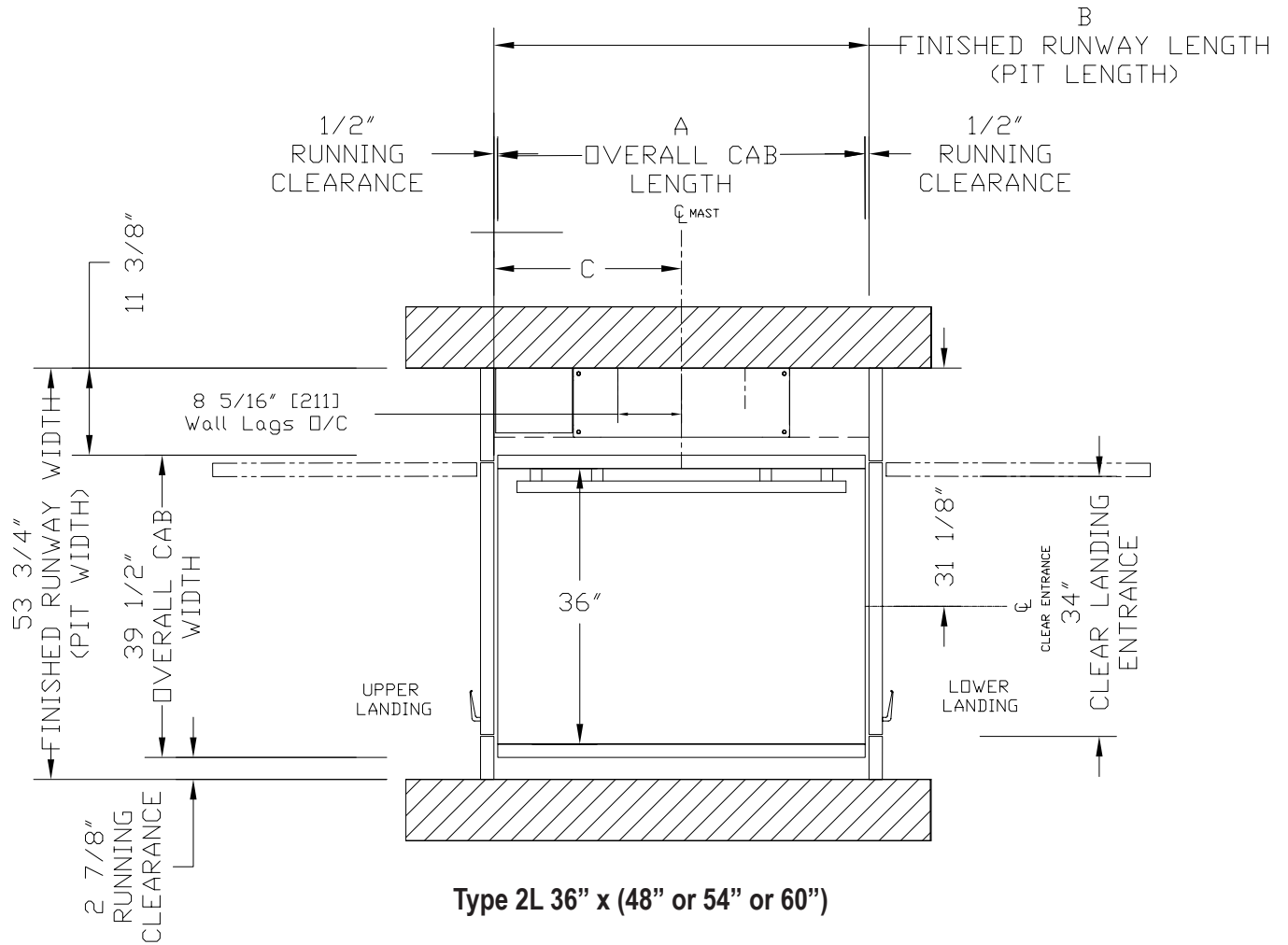

**Type 2L 36" x (48" or 54" or 60")**

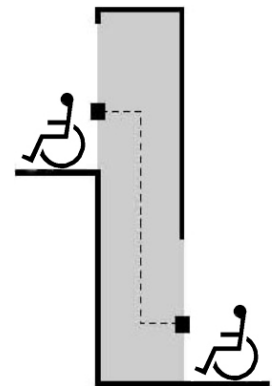
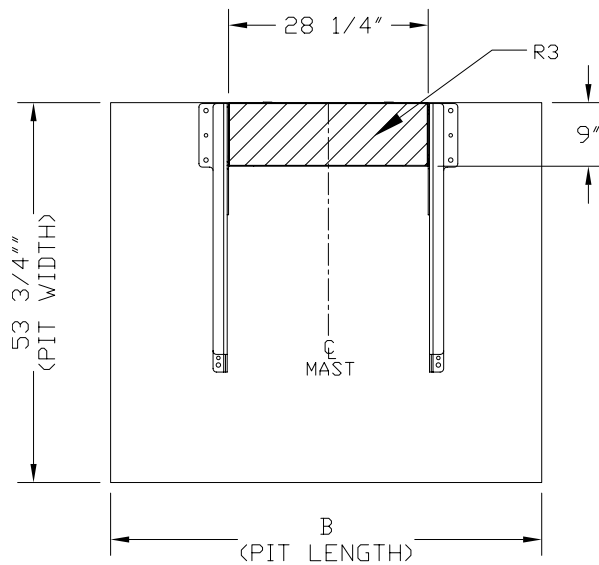

Clear Inside Cab Width	Clear Inside Cab Length	Dimension A	Dimension B	Dimension C
36"	48"	48"	49"	24 1/2"
36"	54"	54"	55"	27 1/2"
36"	60"	60"	61"	30 1/2"

**PLAN DRAWING CAN BE REVERSED FOR RIGHT HAND CONFIGURATIONS.**

# P.A.L. TYPE 2L 42" x 60" HOISTWAY APPLICATION - PLAN VIEW

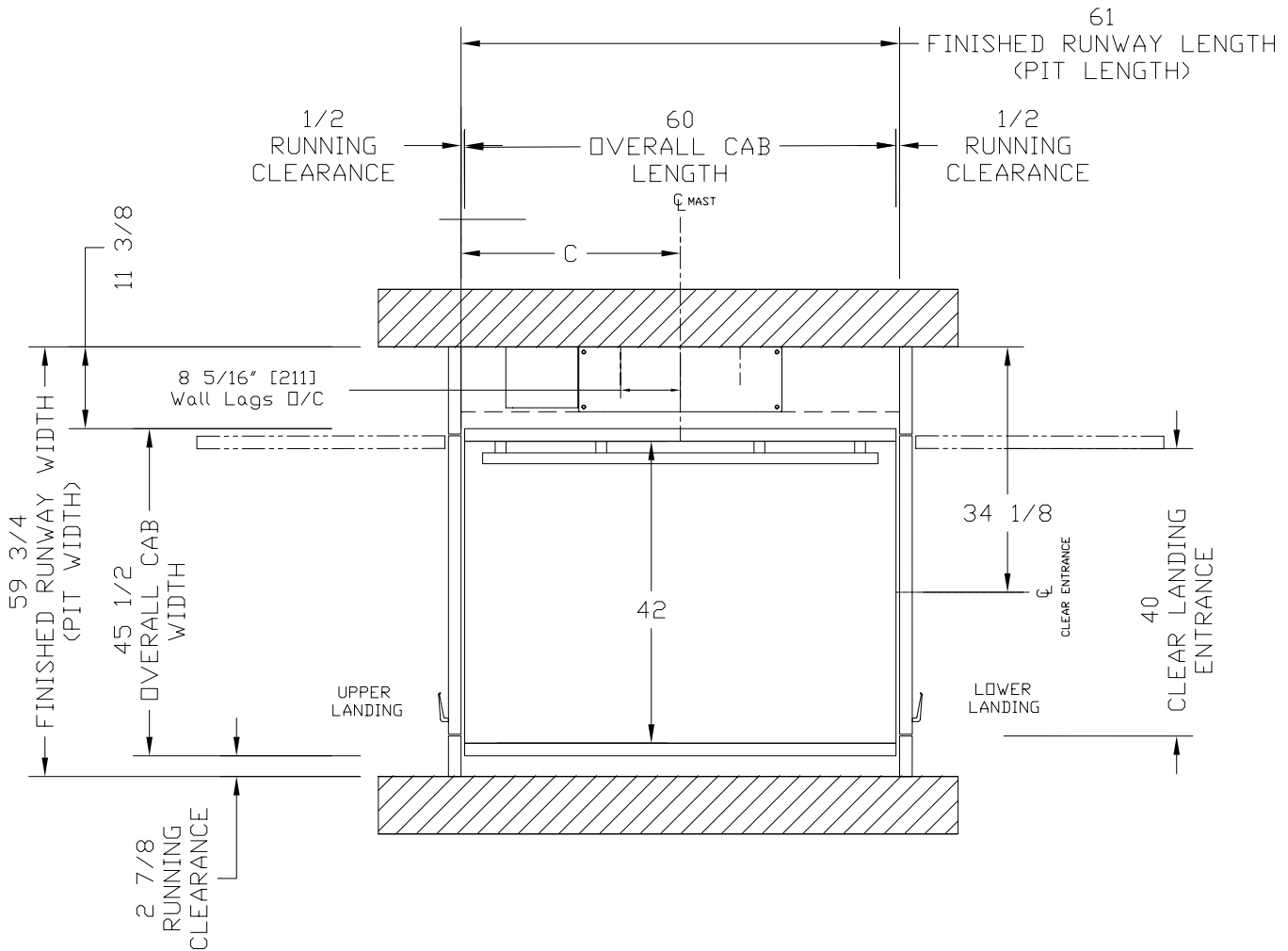

**Type 2L 42" x 60"**

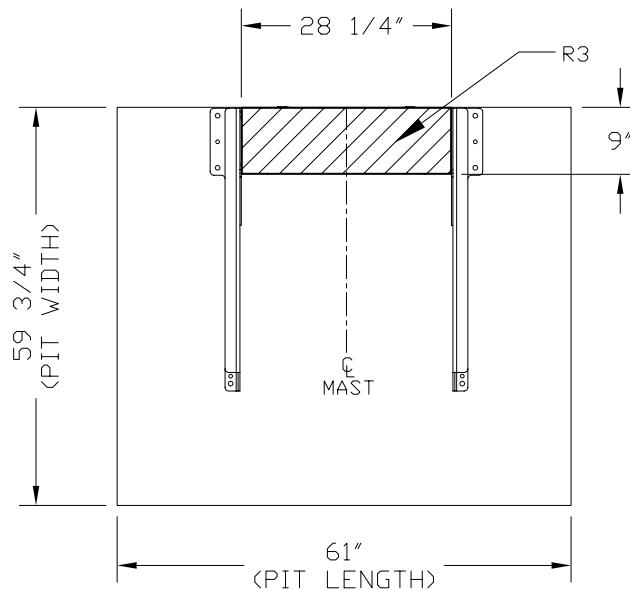
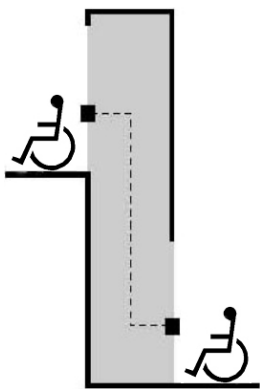

**PLAN DRAWING CAN BE REVERSED FOR RIGHT HAND CONFIGURATIONS.**

**P.A.L. TYPE 3 (OR 4) 42" x 60" HOISTWAY APPLICATION - PLAN VIEW**

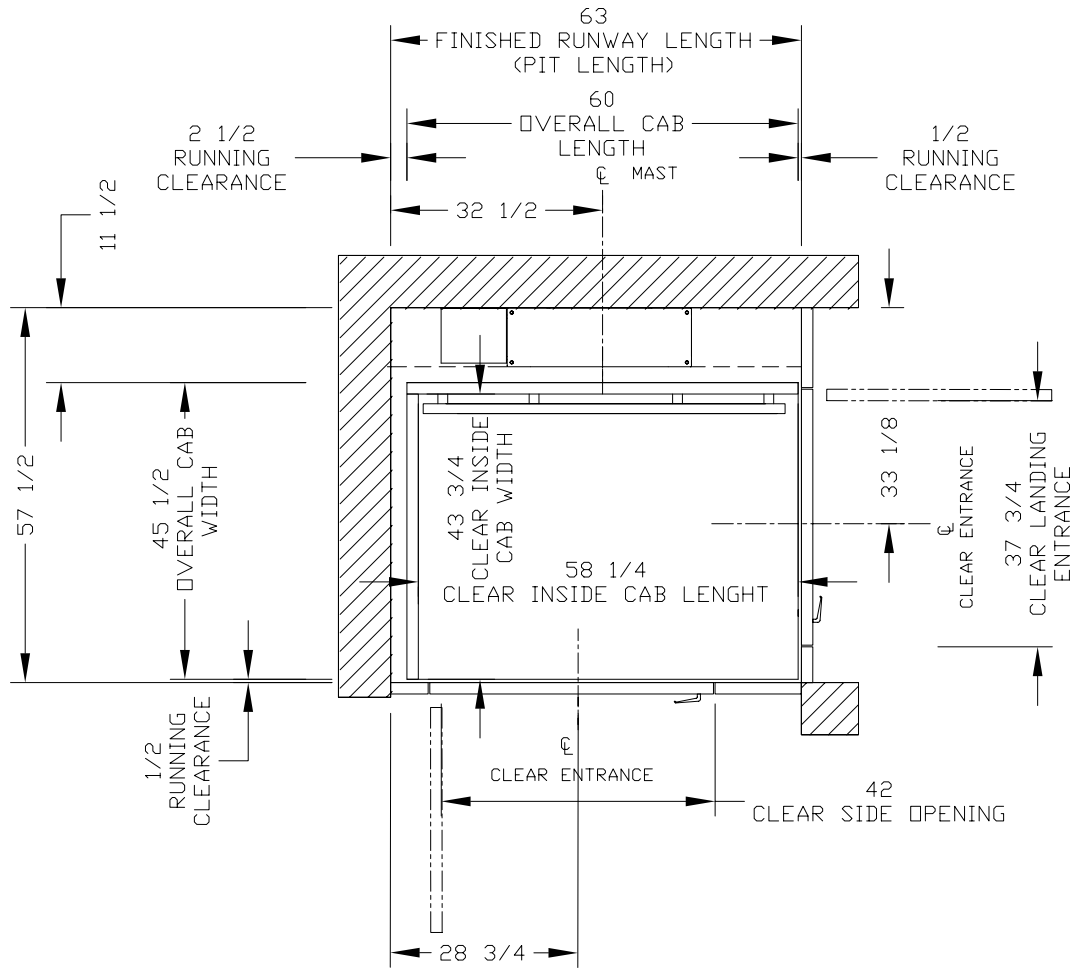

**Type 3 (or 4) 42" x 60"**

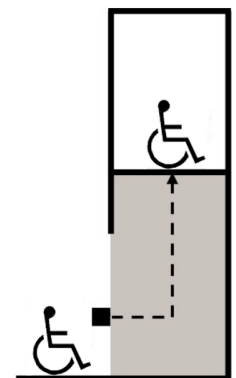
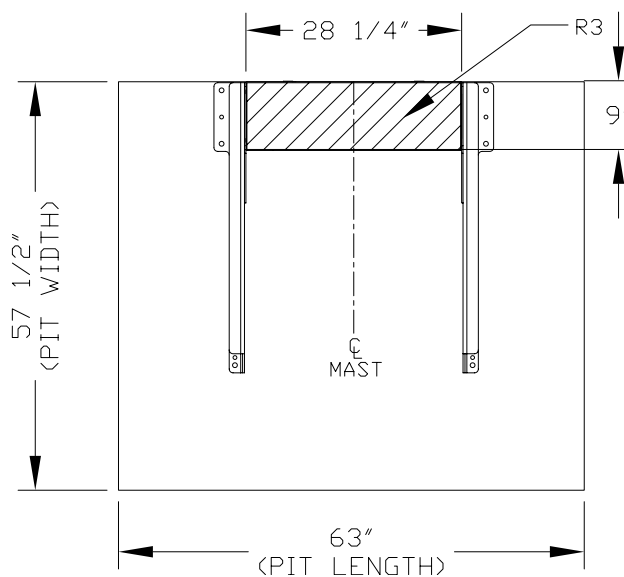

**PLAN DRAWING CAN BE REVERSED FOR TYPE 4 CONFIGURATIONS.**

# P.A.L. ENCLOSURE WITH 43 3/8" UPPER LANDING GATE - ELEVATION VIEW

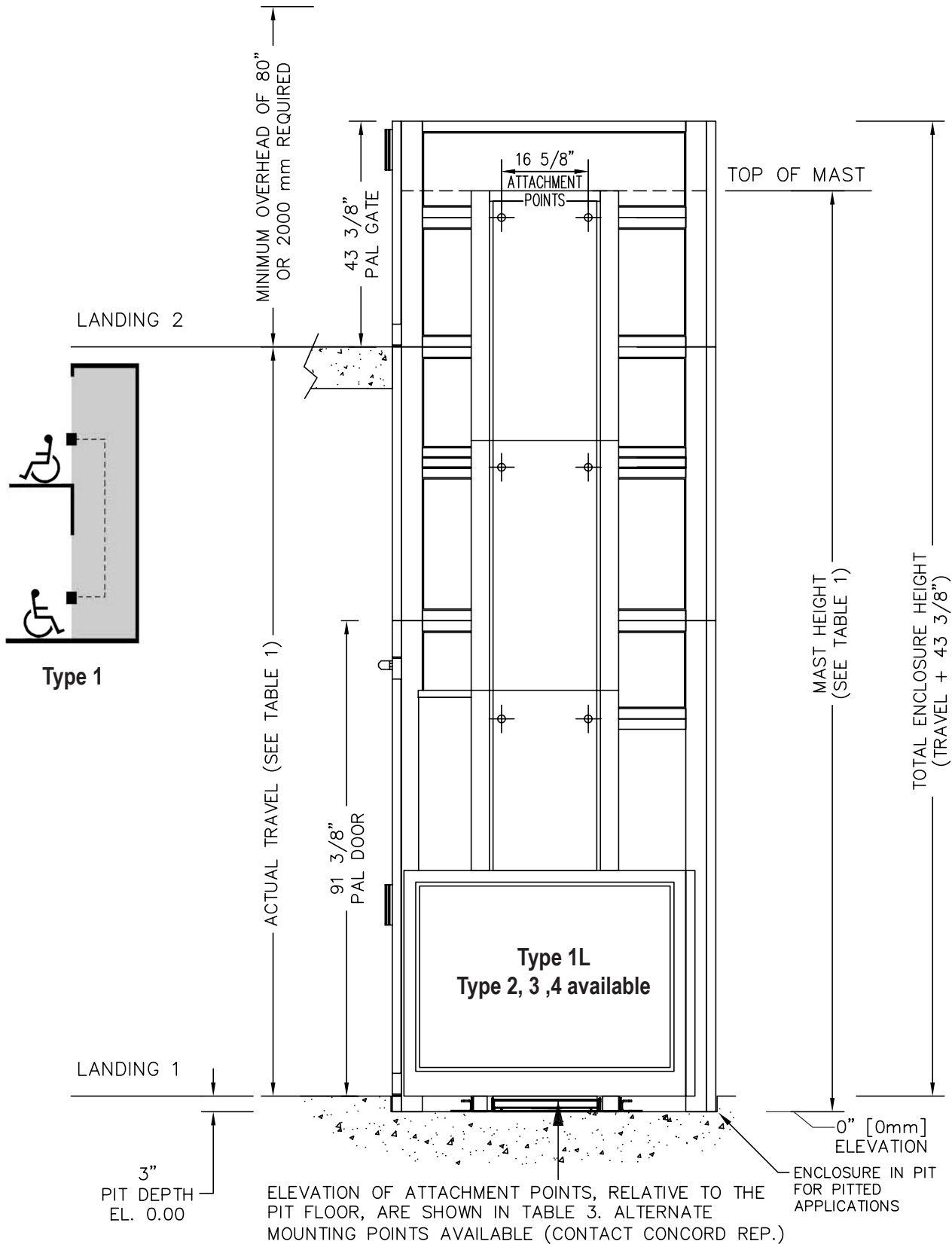

### NOTE

Door and Gate overhead clearances do not include automatic door and gate operators. Custom drawings must be generated to include these options. Enclosure with the pit option shown. For the ramp option, custom drawings must be generated.

**For Type 1 cabs, the minimum mast height is 129".**

**P.A.L. ENCLOSURE WITH UPPER LANDING P.A.L. DOOR AND DOME TOP  
- ELEVATION VIEW**

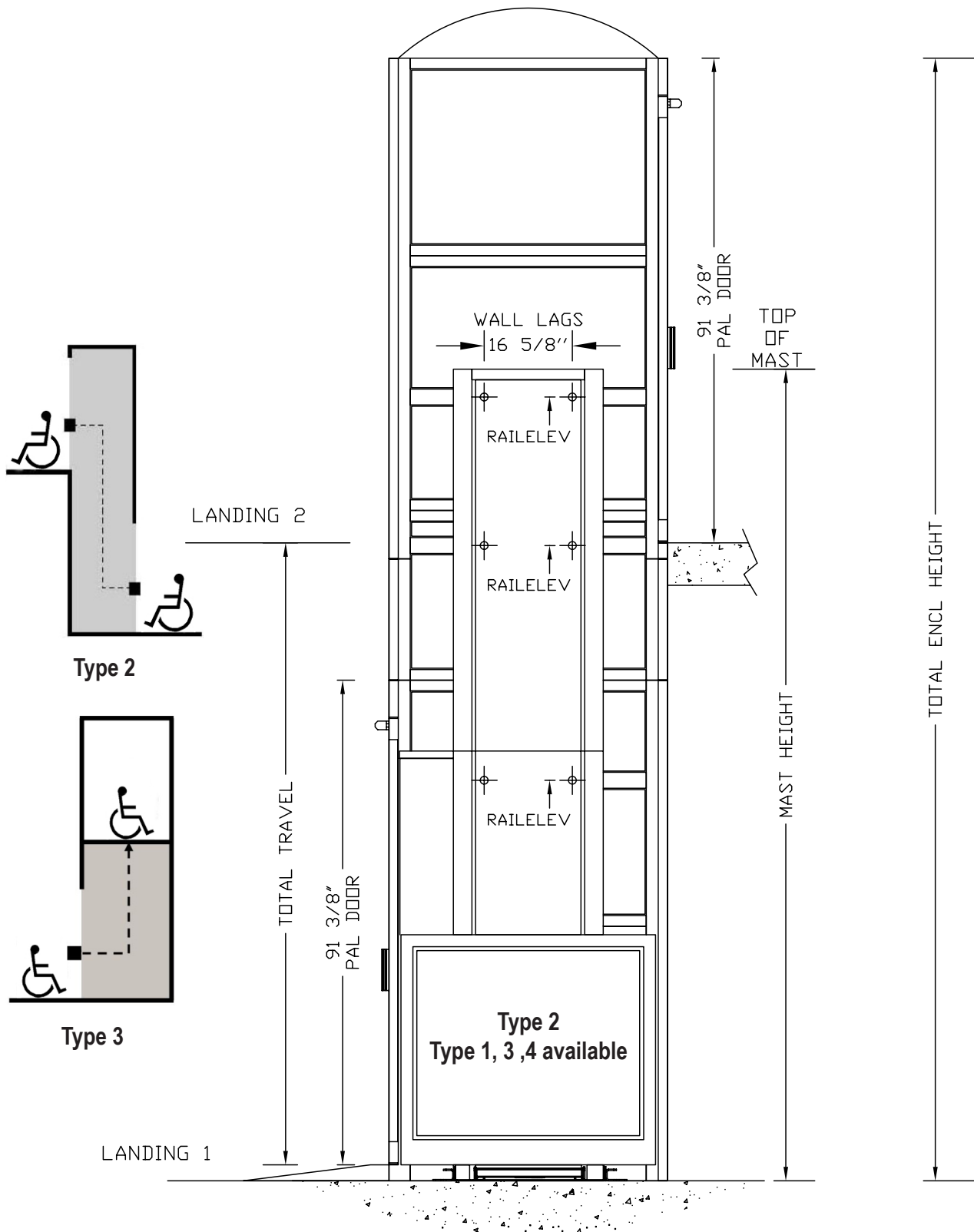

**NOTE**

Door and Gate overhead clearances do not include automatic door and gate operators. Custom drawings must be generated to include these options.

**For Type 1 cabs, the minimum mast height is 129".**

# P.A.L. TYPE 1L 36" x (48" OR 54" OR 60") ENCLOSURE APPLICATION - PLAN VIEW

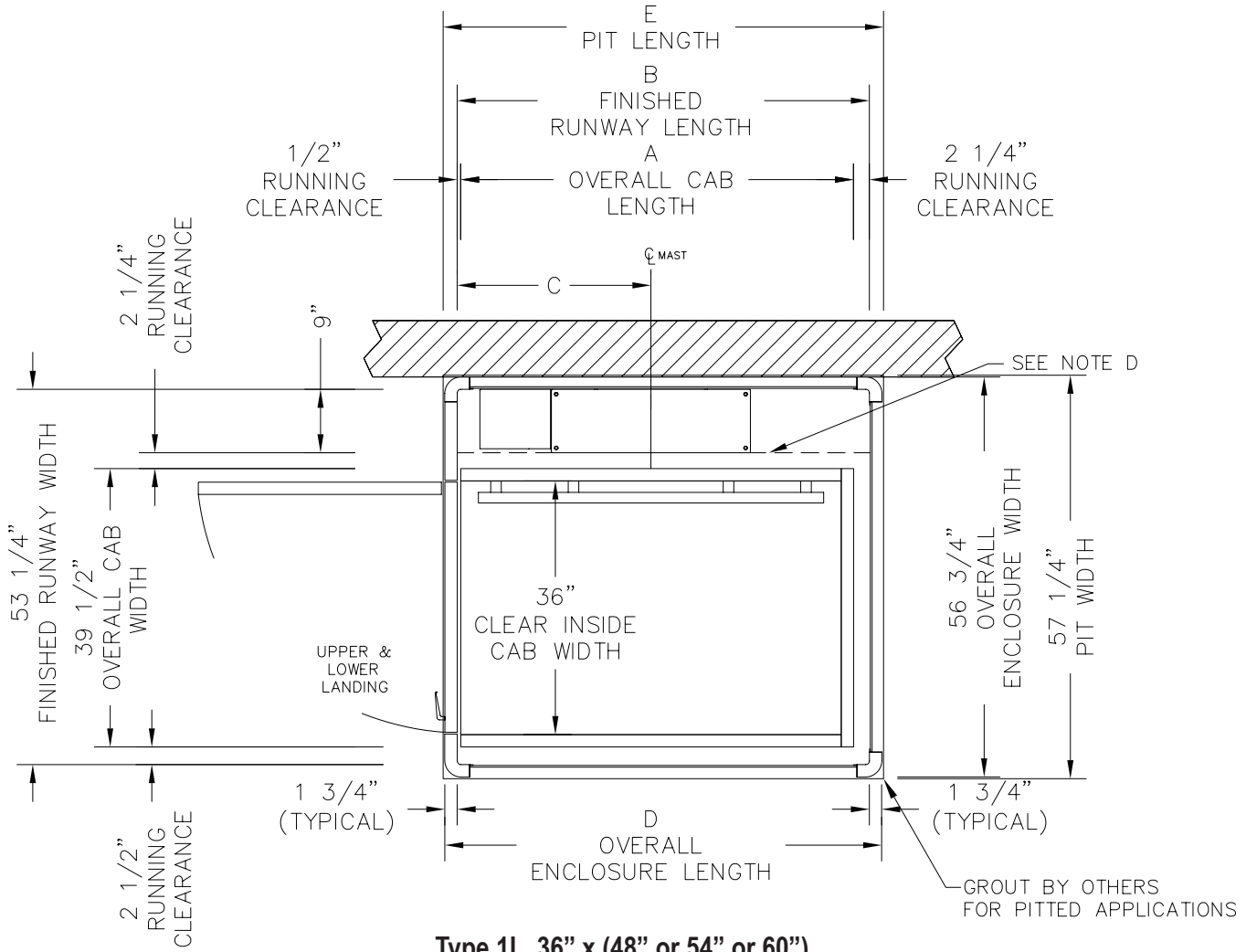

**Type 1L 36" x (48" or 54" or 60")**

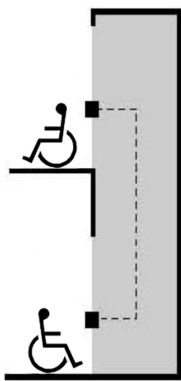

**Type 1**

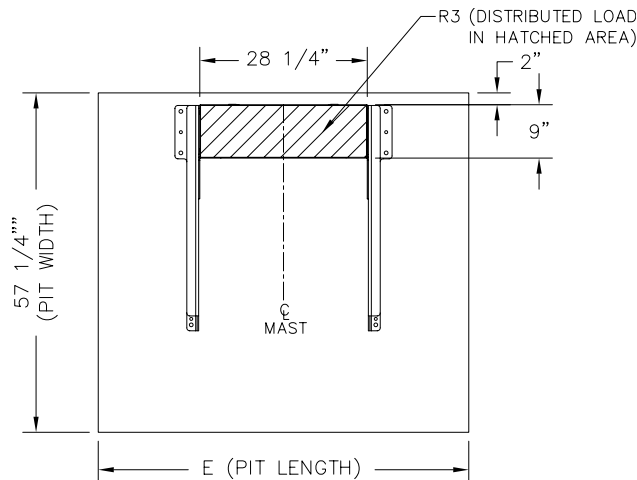

Clear Inside Cab Width	Clear Inside Cab Length	Dimension A	Dimension B	Dimension C	Dimension D	Dimension E
36"	48"	49 3/4"	52 1/2"	24 1/2"	56"	56 1/2"
36"	54"	55 3/4"	58 1/2"	27 1/2"	62"	62 1/2"
36"	60"	61 3/4"	64 1/2"	30 1/2"	68"	68 1/2"

**PLAN DRAWING CAN BE REVERSED FOR RIGHT HAND CONFIGURATIONS.**

# P.A.L. TYPE 1L 42" x 60" ENCLOSURE APPLICATION - PLAN VIEW

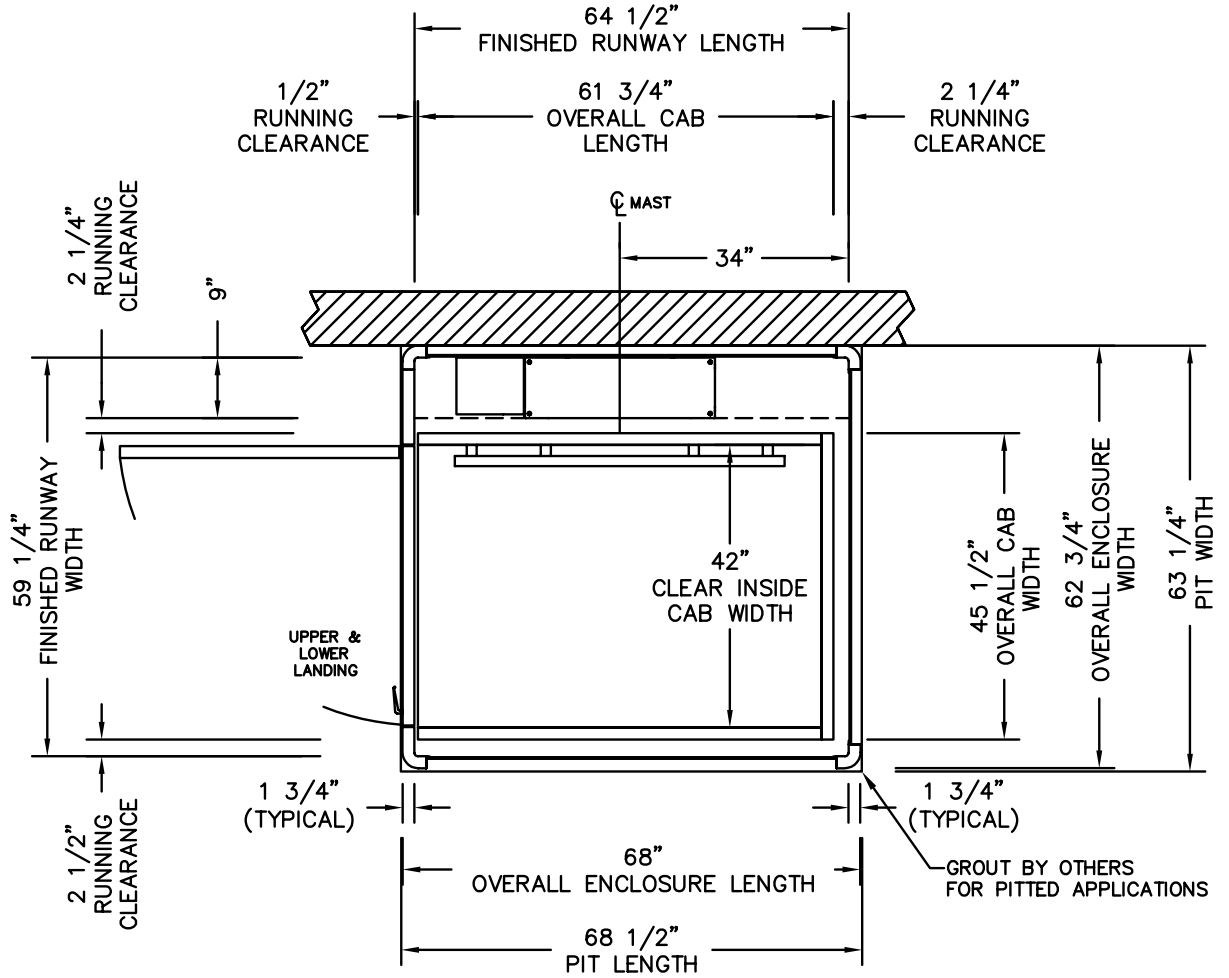

**Type 1L 42" x 60"**

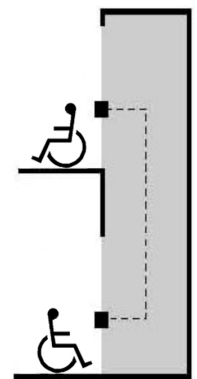
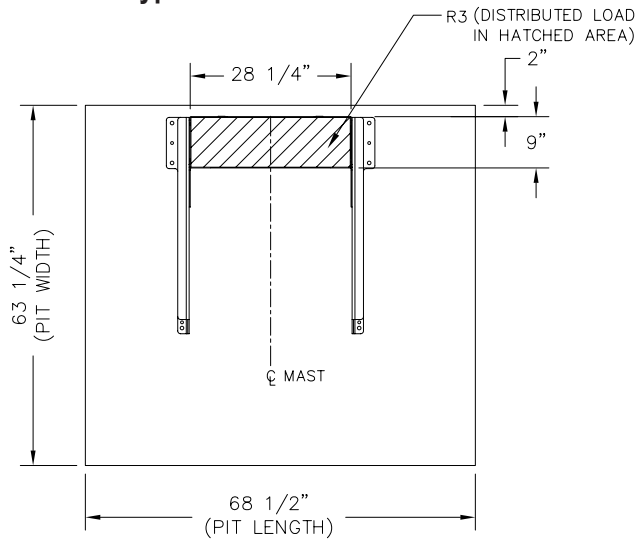

**NOTE**

Enclosure with the pit option shown. For the ramp option, custom drawings must be generated.

**PLAN DRAWING CAN BE REVERSED FOR RIGHT HAND CONFIGURATIONS.**

# P.A.L. TYPE 2L 36" x (48" OR 54" OR 60") ENCLOSURE APPLICATION - PLAN VIEW

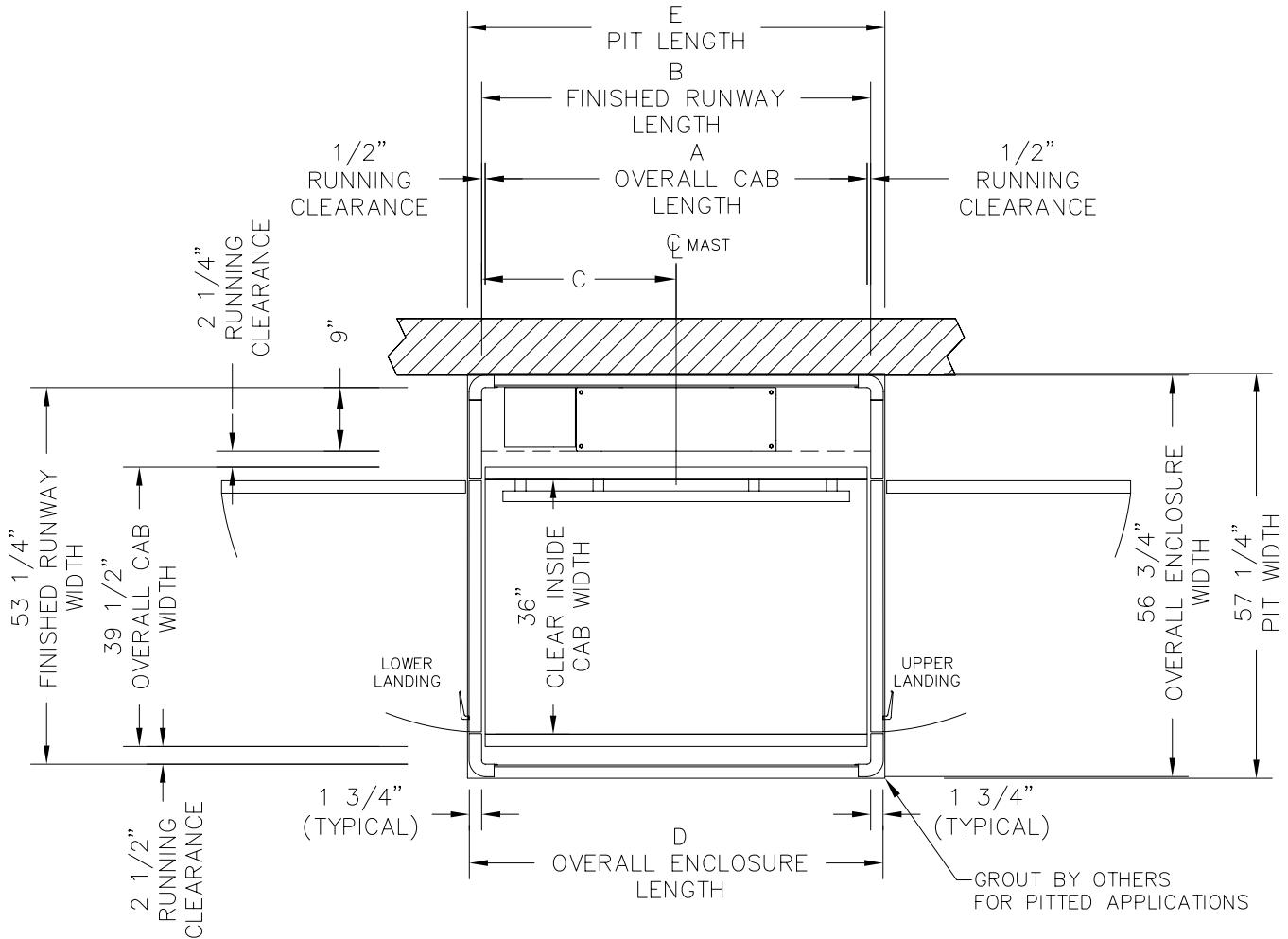

**Type 2L 36" x (48" or 54" or 60")**

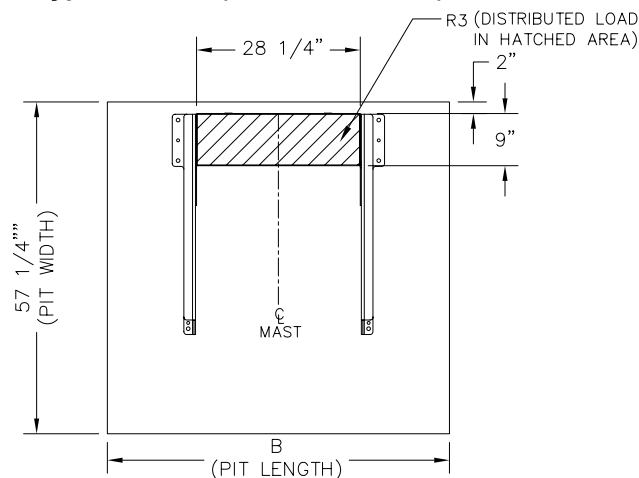
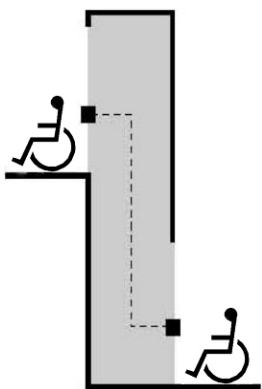

Clear Inside Cab Width	Clear Inside Cab Length	Dimension A	Dimension B	Dimension C	Dimension D	Dimension E
36"	48"	48"	49"	24 1/2"	52 1/2"	53"
36"	54"	54"	55"	27 1/2"	58 1/2"	59"
36"	60"	60"	61"	30 1/2"	64 1/2"	65"

**NOTE**

Enclosure with the pit option shown. For the ramp option, custom drawings must be generated.

**PLAN DRAWING CAN BE REVERSED FOR RIGHT HAND CONFIGURATIONS.**

# P.A.L. TYPE 2L 42" x 60" ENCLOSURE APPLICATION - PLAN VIEW

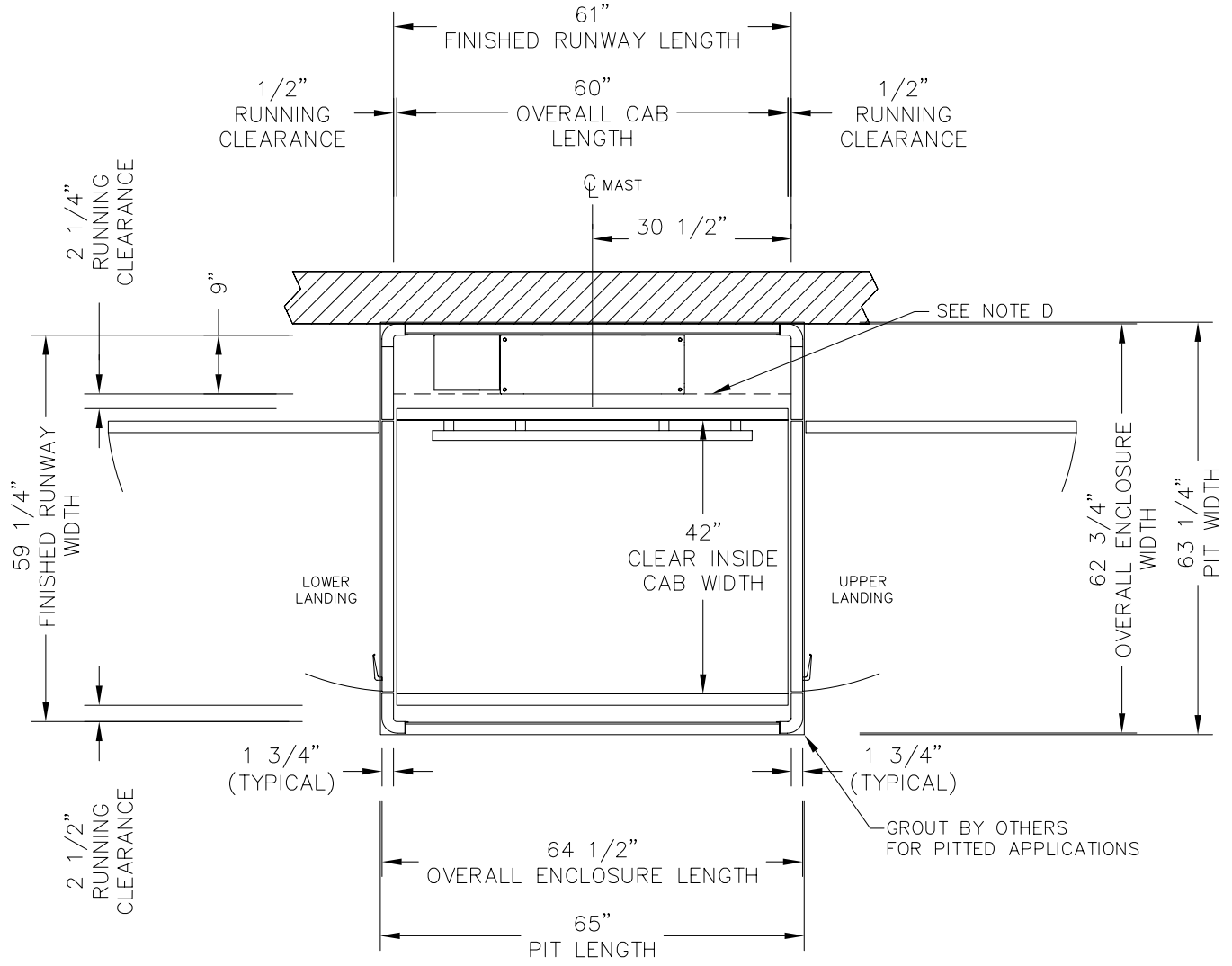

## Type 2L 42"x60"

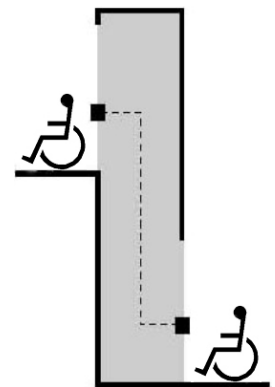
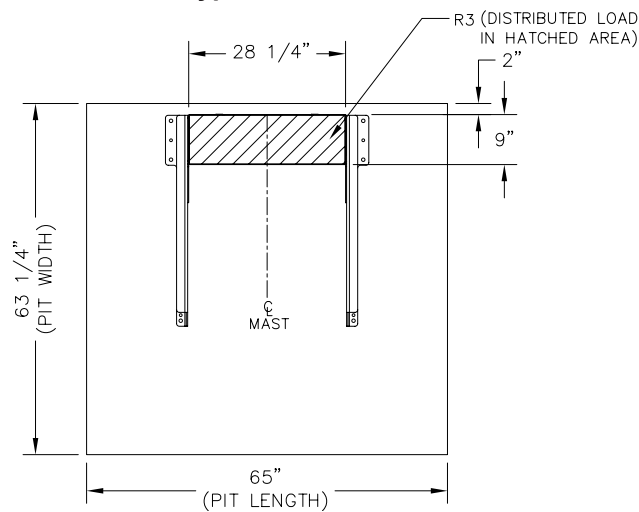

### NOTE

Enclosure with the pit option shown. For the ramp option, custom drawings must be generated.

**PLAN DRAWING CAN BE REVERSED FOR RIGHT HAND CONFIGURATIONS.**

# P.A.L. TYPE 3 (OR 4) 42" x 60" ENCLOSURE APPLICATION -PLAN VIEW

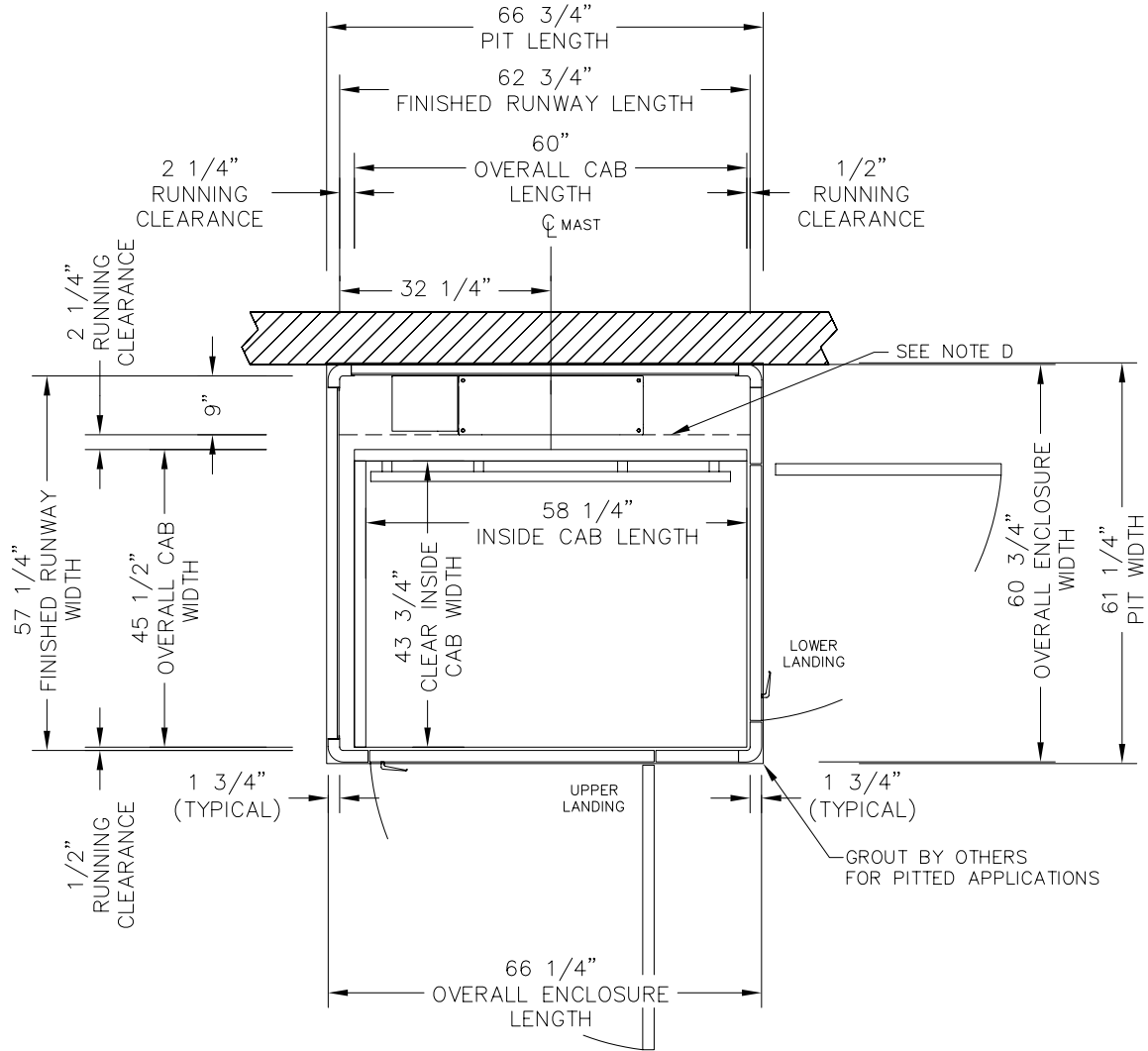

**Type 3 (or 4) 42"x60"**

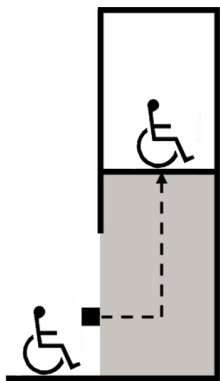

**Type 3**

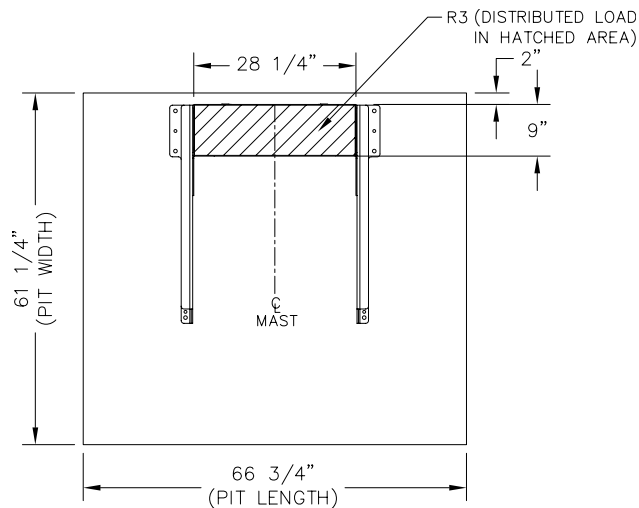

**PLAN DRAWING CAN BE REVERSED FOR TYPE 4 CONFIGURATIONS.**

# Pro Auto and Pro Manual Door Specifications

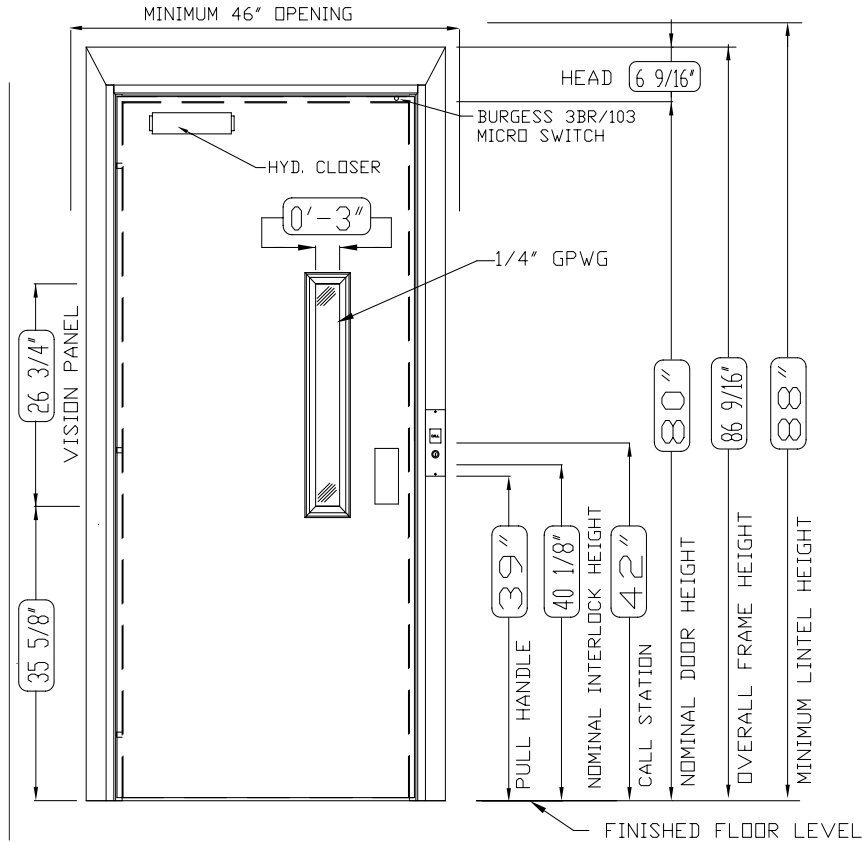

**Pro Manual Fire Rated Door**

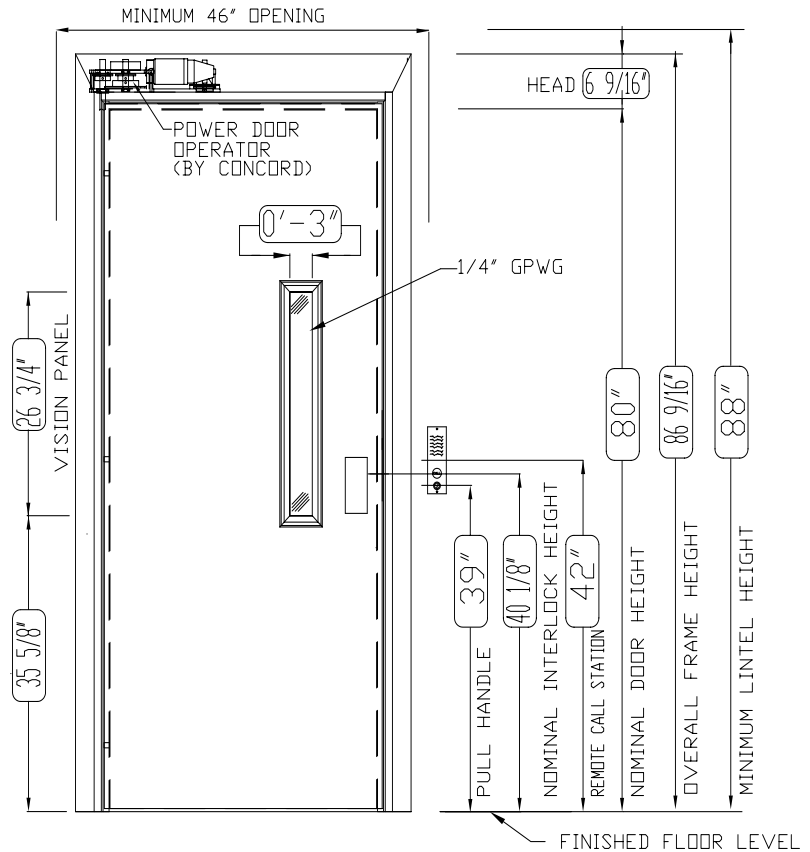

**Pro Auto Fire Rated Door**

**NOTE**

1. See hoistway requirements for the location of the door centerline
2. Door panels and frame on Pro Doors are primed for painting. PAL Doors are Powder Coated to match the lift.
3. Required door frame width is 4" minimum to 8" maximum.

# P.A.L. - S (Standard) Notes

## HOISTWAY

- The hoistway must be designed and built in accordance with “safety standard for platform lifts and stairway chairlifts” (ASME A18.1 sec. 2 or 5) or “safety code for elevators and escalators” (ASME A17.1 sec. 20) and all state and local codes.
- Due to close running clearances owner/agent must ensure that hoistway and pit (where provided) are level, plumb and square and are in accordance with the dimensions on these drawings.

## MINIMUM OVERHEAD CLEARANCE

- Owner/agent must ensure minimum overhead clearance is in compliance with codes.

## CONSTRUCTION SITE

- Owner/agent to provide all masonry, carpentry and drywall work as required and shall patch and make good (including finish painting) all areas where walls/floors may require to be cut, drilled or altered in any way to permit the proper installation of the lift.

## DIMENSIONS

- Contractor/customer to verify all dimensions and report any discrepancies to our office immediately.

## STRUCTURAL

- Structural engineer to assure that building and shaft will safely support all loads imposed by the lift equipment. Refer to the tables on the installation drawing for loads imposed by the equipment.
- Suitable lintels must be provided by owner/agent. Door frames are not designed to support overhead wall loads.

## ELECTRICAL

- Power supply with a lockable fused disconnect (North American 15 amp / International 10 amp) and auxiliary contact to brake the battery feed, or circuit breakers (North American 15 amp / International 10 amp) with a 3-pole breaker for battery feed required in compliance with electrical code (contact your Savaria Concord dealer).
- Permanent power (North American 115 vac 60 hz 1PH / International 220 vac 50 hz 1PH) must be supplied by others before installation.
- Lighting to be supplied by owner/agent to ensure at least 5 ftc or 54 lux ambient lighting over lift area.
- Remote hall call (when supplied) to be installed by the owner/agent at 42” from landing floor.

## ENTRANCES

- Fascia panel below upper level entrance (where required) must be fastened to a solid wall and be perpendicular to the floor and walls.
- Hoistway fascia is not self-supporting for long, continuous runs void of entrances. Adequate support for the fascia must be provided.
- Entrance assemblies must be adjusted to align with platform and interlock equipment. Others to allow an adequate rough opening.
- Return walls at entrances must be built-in by others after entrance assemblies are in place. Entrance assembly must be securely fastened to walls by elevator contractor.

# P.A.L. - EN (Enclosure) Notes

## HOISTWAY

- Due to close running clearances owner/agent must ensure that pit is level, plumb and square with the upper landing and is in accordance with the dimensions shown on these drawings.

## MINIMUM OVERHEAD CLEARANCE

- Owner/agent must ensure minimum overhead clearance is in compliance with this drawing.

## CONSTRUCTION SITE

- Owner/agent to provide all masonry, carpentry and drywall work as required and shall patch and make good (including finish painting) all areas where walls/floors may require to be cut, drilled or altered in any way to permit the proper installation of the lift.

## DIMENSIONS

- Contractor/customer to verify all dimensions and report any discrepancies to our office immediately.

## STRUCTURAL

- Structural engineer to assure that building and shaft will safely support all loads imposed by the lift equipment. Refer to the drawing below and custom installation drawings for loads imposed by the equipment.

## ELECTRICAL

- Power supply with a lockable fused disconnect (North American 15 amp / International 10 amp) and auxiliary contact to brake the battery feed, or circuit breakers (North American 15 amp International 10 amp) with a 3-pole breaker for battery feed required in compliance with electrical code (contact your Savaria Concord dealer).
- Permanent power of (North American 115 vac 60 hz 1PH / International 220 vac 50 hz 1PH) must be supplied by others before installation.
- Lighting to be supplied by owner/agent to ensure at least 5 ftc or 54 lux ambient lighting over lift area.
- Remote hall call (when supplied) to be installed by the owner/agent at 42" from landing floor.

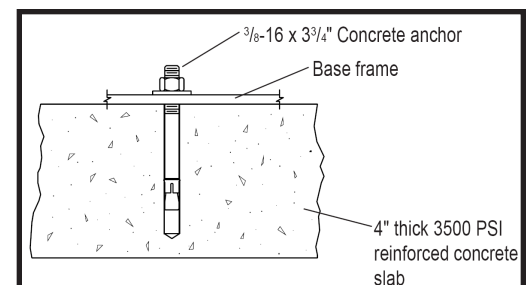
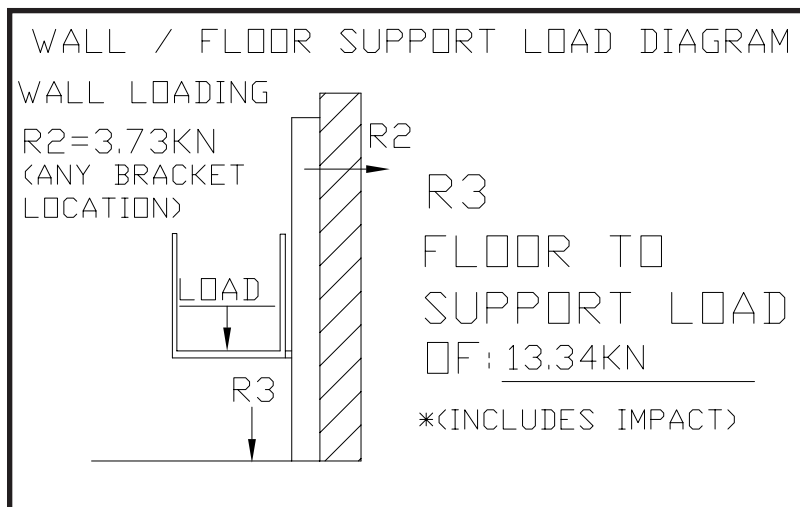

# Specifications for A18.1/B355 Compliance

## SECTION 14420

### WHEELCHAIR LIFTS

#### PART 1 GENERAL

##### 1.01 SUMMARY

- A. A vertical platform (wheelchair) lifting device, manufactured by Savaria Concord Lifts Inc., designed to provide access to or within a building for mobility impaired persons. Lift consists of machine tower and lifting platform selected and dimensioned to provide adequate lifting height to suit building access requirements indoors and out

##### 1.02 REFERENCES

- A. Lift shall be designed, manufactured and installed in accordance with the following standards:
1. American National Standards Institute (ANSI)
  2. American Society of Mechanical Engineers (ASME)
  3. ADA Accessibility Guidelines (ADAAG)
  4. Underwriters Laboratories (UL)
  5. International Building Code (IBC)
  6. National Electrical Code (NEC)
  7. American Society for Testing Materials (ASTM)
  8. American Welding Society (AWS)

##### 1.03 SYSTEM DESCRIPTION

- A. Drive:  
Battery powered 1:2 roped hydraulic drive; ¾ hp, 24 VDC pump motor with two 12 V, 33 AH, sealed no maintenance batteries with 24 V 3.3 amp "smart charge" battery charger
- B. Number of Stops: **(specify:)** 2 stops or 3 stops
- C. Platform Configuration: **(specify:)** straight-through (Type 2), 90° exit (Type 3 or 4) or enter/exit same side (Type 1)
- D. Maximum Travel: **(specify:)** 48", 72", 96", 120", 144" or 168"
- E. Rated Load: 750 lbs. with minimum safety factor of 5X
- F. Rated Speed: 15 fpm with rated load
- G. Platform Size: **(specify:)** 36" x 48", 36" x 54", 36" x 60", 42" x 60", with 43 ⅜" high guard panels
- H. Main Power Supply Wiring: Electrical contractor shall provide (North American 115 VAC, single phase, 15 amp, 60 Hz / International 220 VAC, single phase 10 amp 50 Hz) power circuit
- J. Operating Features:
1. Platform Controls: Soft Touch Controls, on/off key switch, emergency stop switch with alarm and illuminated alarm button
  2. Landing Controls: Soft touch controls and on/off key switch **(specify options:)** emergency stop switch with alarm, mounted inside gate/door frames
  3. Constant pressure operation
  4. Grounded electrical system with upper, lower and final limit switches and 24 V operating controls
  5. Platform underpanel equipped with obstruction sensors
  6. Ramp with incline ratio of 12:1 or 8:1 (required if lift is not installed in a pit)
  7. Non-slip surface on platform floor. Ramp w/ checker plate

8. Grab rail on platform
9. Manual lowering device
10. Remote emergency lowering switch
11. Broken rope safety device and flow control valve
12. Pit switch **(where required by code)**
13. Telephone jack or Hands-Free Telephone on platform (optional)
14. Upper Landing Gate/Door: **(specify:)**
  - a. 43 ⅜" high, self-closing gate with Kwiklock™ mechanical interlock and **(specify:)** steel sheet or plexiglass insert panel
  - b. 6 ft 8" self closing, flush mount, 1 ½ hour fire rated door with Prolock™ electrical/mechanical interlock and 3" x 26" glass vision panel.
  - c. 6 ft 8" self closing, flush mount, non-fire rated door with Kwiklock™ electrical/mechanical interlock and 27" x 67" bronze tinted acrylic vision panel.
15. Lower/Middle Landing Door: **(specify:)**
  - a. 6 ft 8" self closing, flush mount, 1 ½ hour fire rated door with Prolock™ electrical/mechanical interlock and 3" x 26" safety glass vision panel
  - b. 6 ft 8" self closing, flush mount, non-fire rated door with Kwiklock™ mechanical interlock and 27" x 67" Plexiglass vision panel.
16. Automatic Gate/Door opener **(optional)**

##### 1.04 QUALITY ASSURANCE

- A. Manufacturer: Provide wheelchair lift manufactured by a firm with a minimum of 25 years experience in fabrication of wheelchair lifts equivalent to those specified
- B. All designs, clearances, workmanship and material, unless specifically excepted, shall be in accordance with all codes having legal jurisdiction
- C. All load ratings and safety factors shall meet or except those specified by all governing agencies with jurisdiction and shall be certified by a professional engineer
- D. Lift shall be subject to applicable state, local and city approval prior to installation and subject to inspection after installation. Determination of and adherence to these regulations is the responsibility of the lift contractor
- E. Welders certified in accordance with requirements of AWS D1.1 shall perform all welding of all parts
- F. Substitutions: No substitutions permitted

##### 1.05 WARRANTY

Warranty: Manufacturer shall warrant component parts of the P.A.L. vertical platform lift for a period of 36 months from shipping date. This warranty only applies to products installed and maintained by a Savaria Concord Authorized Dealer in conformance with all applicable local and national codes. The warranty is void if regular inspection and maintenance of product is not being carried out by an Authorized Savaria Concord Dealer in accordance with the recommendations contained in the Owner's Manual. It is the Owner's responsibility to keep records of all such service

## 1.06 MAINTENANCE

- A. The P.A.L.® vertical platform lift must be maintained in accordance with manufacturer's instructions

## PART 2 PRODUCT

### 2.01 MANUFACTURER

- A. Provide P.A.L.® vertical platform lift model manufactured by Savaria Concord Lifts Inc.  
**Contact:** 107 Alfred Kuehne Blvd., Brampton, ON.  
Telephone: (800)661-5112  
Fax: (905)791-2222  
Email: sales@concordelevator.com  
Web site: www.concordelevator.com

### 2.02 MATERIAL

- A. Machine Tower: 16 ga. Stainless Steel sheet
- B. Guide Rail: ¾" x 1 ¼" x ⅛" Stainless Steel Roll Formed Channel
- C. Base Frame: ¼" x Stainless Steel Channel
- D. Lift Weldment: ¼" - ⅜" -12 GA Stainless Steel wall structural steel tubing
- E. Side Guard Panels: Aluminum Extrusion with .09" Aluminum Panels
- F. Front Access Panel: 16 ga. Stainless Steel sheet
- G. Platform: 11 ga. 409 Stainless Steel plate
- H. Access Ramp: ⅜" Aluminum plate

### 2.03 FINISHES

Components shall be prepared with

1. Alkaline detergent wash
2. Clear water rinse
3. Iron phosphate coating
4. Clear water rinse and finished with electrostatically applied and baked thermosetting powder coat finish for indoor or outdoor use. Standard color is architectural white.

### 2.04 ELECTRICAL SYSTEMS

- A. The electrical contractors shall provide (North American 115V, single phase, 15 amp, 60 Hz / International 220V, single phase, 10 amp, 50 Hz) electrical power source connection.
- B. Electrical piping and wiring supplied by others
- C. Final electrical connections performed by lift contractor

## PART 3 EXECUTION

### 3.01 ACCEPTABLE INSTALLERS

- A. Installers shall be experienced in performing work of this section who have specialized in work comparable to that required for this project
- B. Installers shall be certified and trained by the manufacturer

### 3.02 EXAMINATION

- A. Use field dimensions and approved manufacturer's shop drawings to examine substrates, supports and other conditions under which this work is to be performed. Do not proceed with work until unsatisfactory conditions are corrected

### 3.03 INSTALLATION

- A. The P.A.L.® vertical platform lift shall be installed in accordance with manufacturer's instructions and as specified and approved by architect
- B. Landing gates and doors shall be installed by others.

**Electrical piping and doors shall be installed by others. Electrical piping and wiring by others. Final electrical connections and lift adjustments by lift contractor.**

### 3.04 DEMONSTRATION

- A. The lift contractor shall make a final check of the lift's operation with the Owner or Owner's representative present prior to turning the lift over for use. The lift contractor shall determine that operating and safety devices are functioning properly

### END OF SECTION

Notes:

Intent of specification is to broadly outline equipment required but does not cover details of design and construction. Dimensions and specifications are subject to constant change and continually evolving codes and product applications. For additional product information, contact Savaria Concord Lifts Inc. at (800) 661-5112 or www.concordelevator.com.

**Savaria Concord Lifts Inc.**

107 Alfred Kuhne Blvd.

Brampton, ON L6T 4K3

Phone: 905-791-5555

Fax: 905-791-2222

Sales: 800-661-5112

email: [info@concordelevator.com](mailto:info@concordelevator.com)

[www.concordelevator.com](http://www.concordelevator.com)

